

Indiscernible topological variations in DAE networks [☆]

Deepak Patil^a, Pietro Tesi^b, Stephan Trenn^c

^a*Indian Institute of Technology Delhi, India*

^b*University of Florence, Italy, University of Groningen, Netherlands*

^c*University of Groningen, Netherlands*

Abstract

A problem of characterizing conditions under which a topological change in a network of differential algebraic equations (DAEs) can go undetected is considered. It is shown that initial conditions for which topological changes are indiscernible belong to a generalized eigenspace shared by the nominal system and the system resulting from a topological change. A condition in terms of eigenvectors of the nominal system is derived to check for existence of possibly indiscernible topological changes. For homogenous networks this condition simplifies to the existence of an eigenvector of the Laplacian of network having equal components. Lastly, a rank condition is derived which can be used to check if a topological change preserves regularity of the nominal network.

Keywords: Differential Algebraic Equations (DAEs), DAE networks, Time-varying topologies

1. Introduction

Control theory of dynamical networks and multi-agent systems has gained enormous popularity in the last years because it involves numerous important applications, as well as many unsolved mathematical questions. In the engineering domain, dynamical networks and multi-agent systems networks naturally arise in cooperative robotics, surveillance and environment monitoring (Ögren et al., 2004; Beard et al., 2006; Arcaç, 2007), as well as man-made infrastructures such as electrical power grids (Chakraborty and Khargonekar, 2013) and transportation networks (Banavar et al., 2000).

Networks can be modelled in terms of a graph, where the nodes represent the various network agents and the edges represent the interaction among the nodes. The overall network dynamics is then the result of the dynamics of each node and the network topology (the interconnection structure formed by the edges). It is known that topology variations may have a major impact on the network behavior. In sensor networks, transceiver failures may significantly degrade the system performance (Bai et al., 2011). In power systems, the failure of a transmission line may even affect the network secure operations (Zhu and Giannakis, 2012). Because of that, the study of network stability/performance in the presence of time-varying topologies has evolved into an active area of research. Most of the research works in this area, however, have focused only on understanding how topological changes affect the network

collective behavior, while little is known on whether topological changes can be actually revealed, which is fundamental to monitor and assess the network state-of-health. In fact, in many practical situations the occurrence of a topological variation cannot be revealed by direct instrumentation; in contrast, they must be inferred by monitoring the network evolution. This is the case for instance in distribution networks where information about the topology is usually not available directly and must be inferred from indirect sensor data like PMUs (Cavvaro et al., 2015).

In the literature, most of the research works dealing with the problem of detecting network topological changes have focused on algorithms for on-line detection (detectors). Examples are methods based on detecting jumps in the measurements (Rahimian and Preciado, 2015), signature-based methods (Cavvaro et al., 2015), Kalman-based approaches (Costanzo et al., 2017), approaches based on nearest neighbor communication (Baroah, 2008) and methods based on orthogonal matching pursuit and the LASSO (Zhu and Giannakis, 2012). Whatever the specific algorithm, a basic and largely unexplored question remains on what are the theoretical limitations to the detection problem (detectability). This amounts to asking whether there are topological changes which cannot be detected irrespective of the specific detection algorithm one is willing to use. To the best of our knowledge, all the research works addressing the issue of detectability consider networks whose dynamics can be fully described in terms of differential equations (Rahimian et al., 2012; Dhal et al., 2013; Rahimian and Preciado, 2015; Torres et al., 2015; Battistelli and Tesi, 2015, 2017; Costanzo et al., 2017). In contrast, there are no results dealing with dynamics that obey differential-algebraic equations (DAEs),

[☆]This work was supported by DFG-project TR 1223/2-1 and SERB-project ECR/2017/003404. It was partly carried out while the first and last author were at the University of Kaiserslautern, Germany.

which naturally arise in the presence of mass and energy balance constraints as in water distribution and electrical circuits. A preliminary result in this direction is our conference publication (Küstners et al., 2017) which only considers the SISO case and also does not characterize the set of network states leading to undetectable topological changes. In this paper we provide a thorough investigation of the detectability problem for a general class of DAE networks, which also involve multivariable and heterogeneous dynamics.

We consider networks of DAEs with diffusive coupling, and study under what conditions topological changes (in particular, a removal or addition of an edge) cannot be detected from observations of the network dynamics, referring to this event as “*indiscernibility*”. We approach this problem from the perspective of control theory and provide necessary and sufficient conditions for indiscernibility that depend on the common eigenspaces of the nominal (before the addition/removal of an edge) and modified network configuration. In this respect, a very interesting result is that indiscernibility can be checked by only looking at the eigenspace of the nominal network configuration. In many practical cases, the latter is usually known in advance since it represents the configuration with which the network is designed to operate. This renders the approach appealing from a practical viewpoint since it allows one to check the existence of indiscernible topological changes with no need to look at all the possible modified topologies. Another interesting result is that the considered approach is general enough so as to include the case where each network node obeys different dynamics, and has possibly different state dimension.

The results presented here establish fundamental limitations to the problem of detecting topological changes from measurements, that is limitations which hold irrespective of the specific detection algorithm (detector) one is willing to use. The problem of designing detectors is left for future research, and it is discussed in more details in the paper conclusions. Finally we would like to note that detecting topological changes can be seen as part of the more general problem of network identifiability (Timme, 2007; Chowdhary et al., 2011; Sanandaji et al., 2011; Nabavi and Chakraborty, 2016; Angulo et al., 2017). In fact, checking whether or not two different network configurations can generate the same dynamics can also be approached by asking under what conditions one can uniquely identify from observations the coupling parameters of the network. However, the problem considered here has much more “structure” than a generic topology identification problem. For example, identification approaches do not assume prior knowledge of a nominal network configuration. In the present context, this knowledge makes it possible to provide conditions on discernibility that can be checked by only looking at the properties of the nominal network configuration.

This paper is organized as follows. First, we define a nominal network of DAEs and obtain a resulting overall

DAE. We also note the effect of addition/removal of an edge on the overall DAE and characterize it as a rank one update to system matrix. Then, we introduce the notion of indiscernibility and bring out a connection between indiscernibility and existence of common generalized eigenspace. This leads to a simple condition on the nominal network which can be used to characterize all topological changes which are possibly indiscernible. Afterwards, we consider a special case of homogeneous networks and obtain a condition for possibly indiscernible topological change which can be checked solely from eigenvectors of the Laplacian of nominal network. Lastly, we give a simple rank condition which helps us check whether a topological change is regularity preserving.

2. System class

We consider a family of $N \in \mathbb{N}$ differential algebraic equations (DAEs),

$$\begin{aligned} E_i \dot{x}_i &= A_i x_i + B_i u_i, & i \in \{1, 2, \dots, N\}, \\ y_i &= C_i x_i, \end{aligned} \quad (1)$$

where $E_i, A_i \in \mathbb{R}^{n_i \times n_i}$, $n_i \in \mathbb{N}$, $B_i, C_i^\top \in \mathbb{R}^{n_i \times p}$, $p \in \mathbb{N}$. Note that each system can have its own state dimension and we allow multiple inputs and outputs (but with the same number p for all systems). Furthermore, we do *not* assume that the individual systems are regular (i.e. we allow that $\det(sE_i - A_i)$ is identically zero for some or all i); in particular, without the coupling with the other systems the individual systems may not have solutions for all inputs u_i and solutions, if they exist, may not be uniquely determined by the initial value and the input. We will however assume that the overall networks dynamics are described by a regular DAE, see Section 6 for more details.

The systems are coupled with each other via diffusive coupling, i.e. for a given undirected coupling graph $\mathfrak{G} = (\mathfrak{V}, \mathfrak{E})$ with vertices $\mathfrak{V} = \{1, 2, \dots, N\}$ and edges $\mathfrak{E} \subseteq \mathfrak{V} \times \mathfrak{V}$; the input of the i -th system is determined by the output of all neighbouring systems as follows:

$$u_i = \sum_{k:(i,k) \in \mathfrak{E}} w_{ik} (y_k - y_i), \quad (2)$$

where $w_{ij} > 0$ with $w_{ji} = w_{ij}$ for $i, j \in \mathfrak{V}$.

Let the weighted Laplacian matrix $\mathfrak{L} = [\ell_{i,j}]_{i,j \in \mathfrak{V}}$ of the graph \mathfrak{G} be given by

$$\ell_{ij} = \begin{cases} -w_{ij}, & i \neq j, (i,j) \in \mathfrak{E}, \\ 0, & i \neq j, (i,j) \notin \mathfrak{E}, \\ \sum_{k:(i,k) \in \mathfrak{E}} w_{ik}, & i = j; \end{cases} \quad (3)$$

note that $\mathfrak{L} \in \mathbb{R}^{N \times N}$ is a symmetric and positive semidefinite matrix. We then can write the coupled dynamics in compact form as

$$\mathcal{E} \dot{x} = (\mathcal{A} - \mathcal{B}(\mathfrak{L} \otimes I_p)\mathcal{C})x =: \mathcal{A}_{\mathfrak{L}} x, \quad (4)$$

where, for $n := \sum_{i=1}^N n_i$,

$$\begin{aligned} x &:= (x_1^\top, x_2^\top, \dots, x_N^\top)^\top, \\ \mathcal{E} &:= \text{diag}\{E_1, \dots, E_N\} \in \mathbb{R}^{n \times n}, \\ \mathcal{A} &:= \text{diag}\{A_1, \dots, A_N\} \in \mathbb{R}^{n \times n}, \\ \mathcal{B} &:= \text{diag}\{B_1, \dots, B_N\} \in \mathbb{R}^{n \times Np}, \\ \mathcal{C} &:= \text{diag}\{C_1, \dots, C_N\} \in \mathbb{R}^{Np \times n}, \end{aligned}$$

and $\mathfrak{L} \otimes I_p \in \mathbb{R}^{Np \times Np}$ denotes the usual Kronecker product of $\mathfrak{L} \in \mathbb{R}^{N \times N}$ with the identity matrix $I_p \in \mathbb{R}^{p \times p}$.

3. Indiscernible initial states

In the following we are interested in the effect of a topological change in the coupling structure and its effect on the systems dynamics. In particular, we are interested in characterizing topological change which do *not* result in changes in the dynamics (for certain initial values). A topological change in the form of a removal/addition of an edge or, more general, a change in the edge weight, results in a change of the description (4) where \mathfrak{L} is replaced by the new Laplacian matrix $\bar{\mathfrak{L}}$ while all other matrices ($\mathcal{E}, \mathcal{A}, \mathcal{B}, \mathcal{C}$) remain unchanged.

Definition 1 (Indiscernible initial states). Consider the coupled system (4). An initial value $x_0 \in \mathbb{R}^n$ is called *indiscernible* with respect to the topological change $\mathfrak{L} \rightarrow \bar{\mathfrak{L}}$ iff for all solutions x of $\mathcal{E}\dot{x} = \mathcal{A}x$ and all solutions \bar{x} of $\mathcal{E}\bar{x} = \mathcal{A}\bar{x}$ the following implication holds:

$$x(0) = x_0 = \bar{x}(0) \implies x(t) = \bar{x}(t) \quad \forall t \in \mathbb{R}.$$

Note that $x_0 = 0$ is always an indiscernible initial state (independently of the specific topological variation) and for certain topological variations it may be the only indiscernible initial state. We are now interested in fully characterizing the set of all indiscernible initial states. Towards this goal we will need to recall some basic properties about eigenvectors of matrix pairs, cf. Berger et al. (2012, Defs. 3.1&3.3).

Definition 2 (Eigenvalues and eigenvector chains). For a matrix pair $(E, A) \in \mathbb{R}^{n \times n} \times \mathbb{R}^{n \times n}$ a complex number $\lambda \in \mathbb{C}$ is called *eigenvalue* if there exists a nontrivial $v \in \mathbb{C}^n \setminus \{0\}$ such that $(A - \lambda E)v = 0$. The set of all eigenvalues of (E, A) is denoted by $\text{spec}(E, A)$.

A tuple of (complex) vectors $(v_1, v_2, \dots, v_k) \in (\mathbb{C} \setminus \{0\})^k$ is called *eigenvector chain (EVC)* of (E, A) for an eigenvalue $\lambda \in \mathbb{C}$ iff v_1 is an eigenvector and for all $i = 2, 3, \dots, k$:

$$(A - \lambda E)v_i = Ev_{i-1}. \quad (5)$$

The *eigenspace of order k* for eigenvalue $\lambda \in \mathbb{C}$ is recursively given by $\mathcal{V}_\lambda^k := \{0\}$ and

$$\mathcal{V}_\lambda^k := (A - \lambda E)^{-1}(E\mathcal{V}_\lambda^{k-1}) \subseteq \mathbb{C}^n;$$

here $(A - \lambda E)^{-1}$ stands for the set-valued preimage ($A - \lambda E$ is not invertible).

The limit $\mathcal{V}_\lambda := \bigcup_{k \in \mathbb{N}} \mathcal{V}_\lambda^k$ of the increasing subspace sequence \mathcal{V}_λ^k is called *generalized eigenspace* for eigenvalue λ ; note that \mathcal{V}_λ^1 is the *space of eigenvectors* corresponding to λ .

When introducing eigenvalues, eigenvectors and eigenvector chains, it is common to assume *regularity* of the matrix pair (E, A) , i.e. the polynomial $\det(sE - A)$ is not identically zero. While this is not strictly necessary, most of the following properties only hold under the regularity assumption and we will mention this additional assumption appropriately.

Note that in addition to the *finite* eigenvalues as defined in Definition 2, a general (regular) matrix pair (E, A) also has *infinite* eigenvalues corresponding to the zero eigenvalue of the reversed matrix pair (A, E) . These infinite eigenvalues and the corresponding EVCs play an important role in the analysis and control of DAEs; however, it turned out that (maybe surprisingly) they are not relevant in the context studied here. In particular, our results are independent of the so called *index* of the overall network DAE.

An interesting characterization for eigenvector chains of a regular matrix pair (E, A) is the following (Berger et al., 2012, Prop. 3.8): (v_1, v_2, \dots, v_k) is an eigenvector chain for eigenvalue $\lambda \in \mathbb{C}$ if, and only if, all (complex-valued) functions, $i = 1, 2, \dots, k$,

$$x_i(t) = e^{\lambda t} [v_1, v_2, \dots, v_i] \left(\frac{t^{i-1}}{(i-1)!}, \dots, \frac{t^2}{2}, t, 1 \right)^\top \quad (6)$$

are linearly independent solutions of $E\dot{x} = Ax$; note that $x_i(0) = v_i$. In fact, the following stronger result holds (which is a simple consequence from the above characterization together with (Berger et al., 2012, Thm 3.6)):

Lemma 3. For a regular matrix pair (E, A) with distinct eigenvalues $\{\lambda_1, \lambda_2, \dots, \lambda_d\} \in \mathbb{C}$ there exists for each $\ell \in \{1, 2, \dots, d\}$ and for each $j \in \{1, 2, \dots, \dim \mathcal{V}_{\lambda_\ell}^1\}$ a number $k_{\ell,j}$ and an eigenvector chain $(v_1^{\ell,j}, v_2^{\ell,j}, \dots, v_{k_{\ell,j}}^{\ell,j})$ for eigenvalue λ_ℓ such that *all* solutions of $E\dot{x} = Ax$ are given by

$$x(t) = \sum_{\ell=1}^d e^{\lambda_\ell t} \sum_{j=1}^{\dim \mathcal{V}_{\lambda_\ell}^1} \sum_{i=1}^{k_{\ell,j}} \alpha_{\ell,j,i} \sum_{\eta=1}^i v_\eta^{\ell,j} \frac{t^{i-\eta}}{(i-\eta)!} \quad (7)$$

and the coefficients $\alpha_{\ell,j,i}$ are *uniquely* determined by the initial value $x(0)$. In particular, the set

$$\left\{ v_i^{\ell,j} \left| \begin{array}{l} \ell \in \{1, \dots, d\}, \\ j \in \{1, \dots, \dim \mathcal{V}_{\lambda_\ell}^1\}, \\ i \in \{1, \dots, k_{\ell,j}\} \end{array} \right. \right\}$$

is linearly independent and the coefficients $\alpha_{\ell,j,i}$ are determined by the unique decomposition

$$x(0) = \sum_{\ell=1}^d \sum_{j=1}^{\dim \mathcal{V}_{\lambda_\ell}^1} \sum_{i=1}^{k_{\ell,j}} \alpha_{\ell,j,i} v_i^{\ell,j}.$$

With the help of *common* EVCs it is now possible to characterize all indiscernible initial states as follows:

Theorem 4. Consider a network with dynamics given by (4) and a regularity preserving¹ topological change $\mathfrak{L} \rightarrow \bar{\mathfrak{L}}$. Let

$$\mathfrak{C}_{\mathfrak{L}, \bar{\mathfrak{L}}} := \left\{ v \in \mathbb{C}^n \left| \begin{array}{l} \exists (v_1, v_2, \dots, v_k) \text{ common EVC of} \\ (\mathcal{E}, \mathcal{A}_{\mathfrak{L}}), (\mathcal{E}, \mathcal{A}_{\bar{\mathfrak{L}}}) \text{ for the same} \\ \text{eigenvalue } \lambda \in \mathbb{C} \text{ and} \\ v = v_i \text{ for some } i \in \{1, 2, \dots, k\} \end{array} \right. \right\}$$

be the set of all vectors which appear in a common eigenvector chain of $(\mathcal{E}, \mathcal{A}_{\mathfrak{L}})$ and $(\mathcal{E}, \mathcal{A}_{\bar{\mathfrak{L}}})$. Then $x_0 \in \mathbb{R}^n$ is an indiscernible initial state for the topological change $\mathfrak{L} \rightarrow \bar{\mathfrak{L}}$ if, and only if, it is in the span of all common eigenvector chains of $(\mathcal{E}, \mathcal{A}_{\mathfrak{L}})$ and $(\mathcal{E}, \mathcal{A}_{\bar{\mathfrak{L}}})$, i.e.

$$x_0 \in \text{span } \mathfrak{C}_{\mathfrak{L}, \bar{\mathfrak{L}}} \cap \mathbb{R}^n.$$

Proof. Sufficiency is easily seen by considering a linear combination of (common) solutions of the form (6).

For showing the converse implication, let us assume that x_0 is indiscernible i.e., $x \equiv \bar{x}$, where x denotes the solution of $\mathcal{E}\dot{x} = \mathcal{A}_{\mathfrak{L}}x$, $x(0) = x_0$ and \bar{x} is the solution of $\mathcal{E}\dot{\bar{x}} = \mathcal{A}_{\bar{\mathfrak{L}}}\bar{x}$, $\bar{x}(0) = x_0$; in particular, x is given by (7), where $(v_1^{\ell, j}, \dots, v_{k_{\ell, j}}^{\ell, j})$ is the j -th eigenvector chain of $(\mathcal{E}, \mathcal{A}_{\mathfrak{L}})$ for eigenvalue λ_{ℓ} and

$$\bar{x}(t) = \sum_{\ell=1}^{\bar{d}} e^{\bar{\lambda}_{\ell} t} \sum_{j=1}^{\dim \bar{\mathcal{V}}_{\bar{\lambda}_{\ell}}^1} \sum_{i=1}^{\bar{k}_{\ell, j}} \bar{\alpha}_{\ell, j, i} \sum_{\eta=1}^i \bar{v}_{\eta}^{\ell, j} \frac{t^{i-\eta}}{(i-\eta)!},$$

where $(\bar{v}_1^{\ell, j}, \dots, \bar{v}_{\bar{k}_{\ell, j}}^{\ell, j})$ is an eigenvector chain of $(\mathcal{E}, \mathcal{A}_{\bar{\mathfrak{L}}})$ for one of the \bar{d} eigenvalues $\bar{\lambda}_1, \dots, \bar{\lambda}_{\bar{d}}$.

Due to the linear independence of the exponential function (with distinct growth rates) it follows that $x \equiv \bar{x}$ is only possible, when there is at least one common eigenvalue (unless $x_0 = 0$). We can reorder the eigenvalues such that for some $r \geq 1$

$$\lambda_1 = \bar{\lambda}_1, \dots, \lambda_r = \bar{\lambda}_r$$

and $\lambda_p \neq \bar{\lambda}_q$ for all $p, q > r$, then $x \equiv \bar{x}$ implies for $\ell = 1, 2, \dots, r$

$$\sum_{j=1}^{\dim \mathcal{V}_{\lambda_{\ell}}^1} \sum_{i=1}^{k_{\ell, j}} \alpha_{\ell, j, i} \sum_{\eta=1}^i v_{\eta}^{\ell, j} \frac{t^{i-\eta}}{(i-\eta)!} = \sum_{j=1}^{\dim \bar{\mathcal{V}}_{\bar{\lambda}_{\ell}}^1} \sum_{i=1}^{\bar{k}_{\ell, j}} \bar{\alpha}_{\ell, j, i} \sum_{\eta=1}^i \bar{v}_{\eta}^{\ell, j} \frac{t^{i-\eta}}{(i-\eta)!} \quad (8)$$

and, for all $\ell > r$ and all corresponding i, j

$$\alpha_{\ell, j, i} = 0, \quad \bar{\alpha}_{\ell, j, i} = 0.$$

By repeatedly taking time-derivatives of (8) and evaluating at $t = 0$ we obtain the following equalities for $\kappa = 0, \dots, \kappa_{\max}^{\ell} := \max\{k_{\ell, j}, \bar{k}_{\ell, j}\} - 1$:

$$w_{\kappa}^{\ell} := \sum_{j=1}^{\dim \mathcal{V}_{\lambda_{\ell}}^1} \sum_{i=1}^{k_{\ell, j}} \alpha_{\ell, j, i} v_{i-\kappa}^{\ell, j} = \sum_{j=1}^{\dim \bar{\mathcal{V}}_{\bar{\lambda}_{\ell}}^1} \sum_{i=1}^{\bar{k}_{\ell, j}} \alpha_{\ell, j, i} \bar{v}_{i-\kappa}^{\ell, j};$$

here we use the convention that quantities indexed outside their actual domain are zero by definition. It then follows for all $\ell = 1, 2, \dots, r$ and all $\kappa = 0, 1, 2, \dots, \kappa_{\max}^{\ell}$:

$$\begin{aligned} (\mathcal{A}_{\mathfrak{L}} - \lambda_{\ell} \mathcal{E}) w_{\kappa}^{\ell} &= \sum_{j=1}^{\dim \mathcal{V}_{\lambda_{\ell}}^1} \sum_{i=1}^{k_{\ell, j}} \alpha_{\ell, j, i} (\mathcal{A}_{\mathfrak{L}} - \lambda_{\ell} \mathcal{E}) v_{i-\kappa}^{\ell, j} \\ &= \sum_{j=1}^{\dim \mathcal{V}_{\lambda_{\ell}}^1} \sum_{i=1}^{k_{\ell, j}} \alpha_{\ell, j, i} \mathcal{E} v_{i-\kappa-1}^{\ell, j} = \mathcal{E} w_{\kappa+1}^{\ell}, \end{aligned}$$

where $w_{\kappa_{\max}^{\ell}+1}^{\ell} := 0$. An analogous calculation shows that

$$(\mathcal{A}_{\bar{\mathfrak{L}}} - \lambda_{\ell} \mathcal{E}) w_{\kappa}^{\ell} = \mathcal{E} w_{\kappa+1}^{\ell};$$

in particular, the tuple $(w_{\kappa_{\max}^{\ell}}^{\ell}, \dots, w_1^{\ell}, w_0^{\ell})$ (note the reversed order) satisfies the eigenvector chain condition (5) and we have shown that

$$x(0) = \sum_{\ell=1}^r w_0^{\ell}$$

is an element of $\text{span } \mathfrak{C}_{\mathfrak{L}, \bar{\mathfrak{L}}}$. □

Remark 5. Note that existence of at least one common eigenvector is both necessary and sufficient for the existence of a nontrivial indiscernible initial condition (because any common eigenvector chain also contains a common eigenvector). But the set of initial conditions which are indiscernible are not limited to the span of common eigenvectors; they are spanned by common eigenvector chains. Only when all (common) eigenvalues are semi-simple (i.e. they do not correspond to Jordan blocks of size bigger than one), the span of common eigenvectors yields the whole space of indiscernible initial states.

4. Indiscernible topological changes

In the design of a suitable network topology (with Laplacian matrix \mathfrak{L}) one goal could be to avoid the existence of any (nontrivial) indiscernible initial state with respect to many fault scenarios $\mathfrak{L} \rightarrow \bar{\mathfrak{L}}$. It is therefore meaningful to define the following properties of a topological change:

Definition 6. For a coupled system (4) a topological change $\mathfrak{L} \rightarrow \bar{\mathfrak{L}}$ is called *always-discernible* if there is no (nontrivial) indiscernible initial state and *possibly-indiscernible* if there exists a nontrivial indiscernible initial state.

¹i.e. the matrix pairs $(\mathcal{E}, \mathcal{A}_{\mathfrak{L}})$, $(\mathcal{E}, \mathcal{A}_{\bar{\mathfrak{L}}})$ are both regular

Note that we do not simply say that a topological change is discernible/indiscernible because the possibility to detect a topological change strongly depends on the initial state. Furthermore, even when a topological change is possibly-indiscernible, it will usually be discernible for *almost all* initial states, because the subspace of indiscernible initial states is a subspace of dimension usually smaller than n .

Our goal is now to provide a simple characterization of possible-indiscernibility which does not require the calculation of the whole set of indiscernible initial states. The following lemma is a key observation towards this goal:

Lemma 7. Let $(\lambda, v) \in \mathbb{C} \times \mathbb{C}^n \setminus \{0\}$ be an eigenvalue-eigenvector pair of $(\mathcal{E}, \mathcal{A}_{\mathcal{L}})$. Then (λ, v) is also an eigenvalue-eigenvector of $(\mathcal{E}, \mathcal{A}_{\overline{\mathcal{L}}})$ if, and only if,

$$v \in \ker(\mathcal{A}_{\overline{\mathcal{L}}} - \mathcal{A}_{\mathcal{L}})$$

Proof.

$$\begin{aligned} (\mathcal{A}_{\overline{\mathcal{L}}} - \lambda\mathcal{E})v = 0 &\Leftrightarrow (\mathcal{A}_{\overline{\mathcal{L}}} - \mathcal{A}_{\mathcal{L}} + \mathcal{A}_{\mathcal{L}} - \lambda\mathcal{E})v = 0 \\ &\stackrel{(\mathcal{A}_{\mathcal{L}} - \lambda\mathcal{E})v=0}{\Leftrightarrow} (\mathcal{A}_{\overline{\mathcal{L}}} - \mathcal{A}_{\mathcal{L}})v = 0. \end{aligned}$$

□

Utilizing the special structure of $\mathcal{A}_{\overline{\mathcal{L}}} - \mathcal{A}_{\mathcal{L}}$ we can derive the main result of this section:

Theorem 8. Consider a family of DAEs of the form (1) connected by a network graph $\mathfrak{G} = (\mathfrak{N}, \mathfrak{E})$ with weighted Laplacian \mathcal{L} resulting in the overall system (4), which we assume to be regular. Any regularity-preserving removal/addition of the edge (i, j) is a possibly-indiscernible topological change if, and only if, there exists an eigenvector $v \in \mathbb{C}^n \setminus \{0\}$ of $(\mathcal{E}, \mathcal{A}_{\mathcal{L}})$ with

$$(\mathcal{C}v)_i - (\mathcal{C}v)_j \in \ker \begin{bmatrix} B_i \\ B_j \end{bmatrix}; \quad (9)$$

here $(\mathcal{C}v)_k \in \mathbb{R}^p$ (for k either i or j) denotes the k -th (block) entry of the vector $\mathcal{C}v \in \mathbb{R}^{Np}$ consisting in total of N entries of length p .

Proof. The addition/removal of edge (i, j) leads to a topological change $\mathcal{L} \rightarrow \overline{\mathcal{L}}$ with

$$\overline{\mathcal{L}} = \mathcal{L} \pm w_{ij}(e_i - e_j)(e_i - e_j)^\top;$$

hence $v \in \ker(\mathcal{A}_{\overline{\mathcal{L}}} - \mathcal{A}_{\mathcal{L}})$ if, and only if,

$$\mathcal{C}v \in \ker \mathcal{B}((e_i - e_j)(e_i - e_j)^\top \otimes I_p);$$

where we used bilinearity of the Kronecker product and $w_{ij} \neq 0$. It is easily seen that

$$\mathcal{B}((e_i - e_j)(e_i - e_j)^\top \otimes I_p) = \begin{bmatrix} 0 & 0 & 0 & 0 & 0 \\ 0 & \mathcal{B}_i & 0 & -\mathcal{B}_i & 0 \\ 0 & 0 & 0 & 0 & 0 \\ 0 & -\mathcal{B}_j & 0 & \mathcal{B}_j & 0 \\ 0 & 0 & 0 & 0 & 0 \end{bmatrix}, \quad (10)$$

with suitably sized zero matrices. Together with Theorem 4 (in particular, Remark 5) and Lemma 7 this shows the claim of the Theorem. □

Remark 9. The condition (9) derived in Theorem 8 establishes fundamental limitations to the problem of detecting topological changes in DAEs networks with dynamics as in (4). In fact, under (9) there exist edges whose removal/addition can go undetected irrespective of the detection algorithm one is willing to use, even in the most favourable situation where the whole network state is available for measurements. In connection with condition (9), it is worth remarking that this condition does only involve the knowledge of the dynamics of the nodes (the matrices (E_i, A_i, B_i, C_i) , which are usually obtained through a local identification procedure) and the topology of interest (the Laplacian \mathcal{L} , which represents the nominal configuration under which the network should operate). This condition can be therefore checked off-line and without actually measuring the network evolution. The very same conclusions apply to Corollary 14 of Section 5.

Remark 10. The condition (9) derived in Theorem 8 will be satisfied if either $(\mathcal{C}v)_i = (\mathcal{C}v)_j$ or $(\mathcal{C}v)_i - (\mathcal{C}v)_j \in \ker \begin{bmatrix} B_i \\ B_j \end{bmatrix}$. If $(\mathcal{C}v)_i = (\mathcal{C}v)_j$ then there is no diffusion taking place at the edge (i, j) and as a result any addition or removal of edge between i -th and j -th vertex will go undetected. On the other hand, if $(\mathcal{C}v)_i - (\mathcal{C}v)_j \in \ker \begin{bmatrix} B_i \\ B_j \end{bmatrix}$ then the diffusive coupling between i -th and j -th vertex is unable to influence the dynamics at the respective vertices. Thus, any addition or removal of edge between i -th and j -th vertex will once again go undetected. Further, if we assume that input matrices B_i are of full column rank for all i , then condition (9) reduces to $(\mathcal{C}v)_i = (\mathcal{C}v)_j$. It also follows from (9) that a necessary requirement to avoid the existence of a possibly-indiscernible topological change is that the overall dynamics of the network with output $y = \mathcal{C}x$ must be observable in a behavioral sense (Berger et al., 2017). In fact, in the unobservable case there always exists a pair (λ, v) satisfying $\mathcal{A}_{\mathcal{L}}v = \lambda\mathcal{E}v$ along with $\mathcal{C}v = 0$, which implies the fulfilment of (9) regardless of \mathcal{B} . Unobservable states are obviously a particular class of initial states for which no diffusion takes place. Notice that the same conclusions could have been drawn also by looking at Theorem 4 since the existence of a pair (λ, v) satisfying $\mathcal{A}_{\mathcal{L}}v = \lambda\mathcal{E}v$ and $\mathcal{C}v = 0$ implies that $\mathcal{A}_{\mathcal{L}}v = \mathcal{A}_{\overline{\mathcal{L}}}v = \mathcal{A}v$, which means that (λ, v) is a common eigenvalue-eigenvector pair of $(\mathcal{E}, \mathcal{A}_{\mathcal{L}})$ and $(\mathcal{E}, \mathcal{A}_{\overline{\mathcal{L}}})$.

For illustrating the above result, we will present two examples. The first example is the well known Wheatstone bridge with additional grounded capacitors which we recall from (Küstters et al., 2017, Ex. 6); the second example is a 9 bus power grid benchmark from MATPOWER (Zimmerman et al., 2011) which is similar to the Western System Coordinating Council (WSCC) 3-Machine-9-Bus power network (Sauer and Pai, 1998).

Example 11. Consider a circuit as shown in Figure 1.

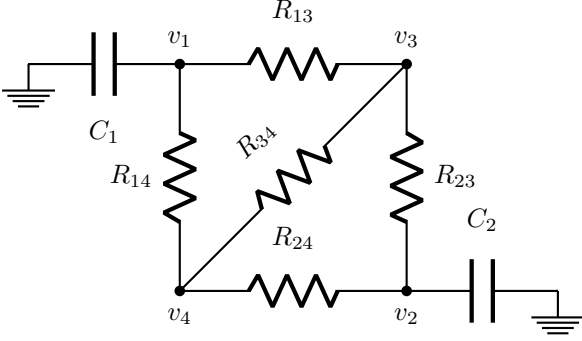

Figure 1: RC-circuit.

Here nodes 1 and 2 are connected to grounded capacitors and hence lead to dynamic equations. On the other hand nodes 3 and 4 lead to algebraic equations. At each node i we have as state variable the potential v_i , which is also the output y_i , and as input the total current u_i flowing into this node (via a resistive edge); the relationship of state, input and output is described by a DAE for each node as follows.

$$\begin{aligned} \text{Node 1 :} & \quad C_1 \dot{v}_1 = u_1, & y_1 &= v_1, \\ \text{Node 2 :} & \quad C_2 \dot{v}_2 = u_2, & y_2 &= v_2, \\ \text{Node 3 :} & \quad 0 = u_3, & y_3 &= v_3, \\ \text{Node 4 :} & \quad 0 = u_4, & y_4 &= v_4. \end{aligned}$$

Note that the DAEs at node 3 and 4 are non-regular: The state variables v_3 and v_4 are completely free, and the input variables u_3 and u_4 are not arbitrary. The nodes are coupled via resistors, which lead to the following coupling conditions:

$$\begin{aligned} u_1 &= R_{14}(v_4 - v_1) + R_{13}(v_3 - v_1), \\ u_2 &= R_{24}(v_4 - v_2) + R_{23}(v_3 - v_2), \\ u_3 &= R_{13}(v_1 - v_3) + R_{23}(v_2 - v_3) + R_{34}(v_4 - v_3), \\ u_4 &= R_{14}(v_1 - v_4) + R_{24}(v_2 - v_4) + R_{34}(v_3 - v_4). \end{aligned}$$

The overall system equation is given by (4) with

$$\mathcal{E} = \begin{bmatrix} C_1 & 0 & 0 & 0 \\ 0 & C_2 & 0 & 0 \\ 0 & 0 & 0 & 0 \\ 0 & 0 & 0 & 0 \end{bmatrix}, \quad \mathcal{A} = 0_{4 \times 4}, \quad \mathcal{B} = I_4, \quad \mathcal{C} = I_4$$

and

$$\mathcal{L} = \begin{bmatrix} R_{13}+R_{14} & 0 & -R_{13} & -R_{14} \\ 0 & R_{23}+R_{24} & -R_{23} & -R_{24} \\ -R_{13} & -R_{23} & R_{13}+R_{23}+R_{34} & -R_{34} \\ -R_{14} & -R_{24} & -R_{34} & R_{14}+R_{24}+R_{34} \end{bmatrix}.$$

In this case, equation (4) reduces to

$$\mathcal{E}\dot{v}(t) = -\mathcal{L}v(t). \quad (11)$$

Assuming equal values of magnitude one for all the resistances and capacitances in this circuit, we compute the

eigenvalues and eigenvectors of the matrix pair $(\mathcal{E}, -\mathcal{L})$. There are two finite eigenvalues $\lambda_1 = 0$ and $\lambda_2 = -2$ with corresponding eigenvectors

$$v^1 = \begin{pmatrix} 1 \\ 1 \\ 1 \\ 1 \end{pmatrix}, \quad v^2 = \begin{pmatrix} 1 \\ -1 \\ 0 \\ 0 \end{pmatrix}.$$

Clearly, both the eigenvectors are such that $(Cv)_3 - (Cv)_4 = 0$ is satisfied. Thus, by Theorem 8, the addition/removal of edge (3, 4) is indiscernible for “any” consistent initial value.

Example 12. We consider a power grid model which is similar to the WSCC 3-machine 9-bus power network consists of 3 generators and 9 buses; the generators are connected to buses 1, 2, 3 and loads are connected on buses 4, ..., 9 (see Figure 2).

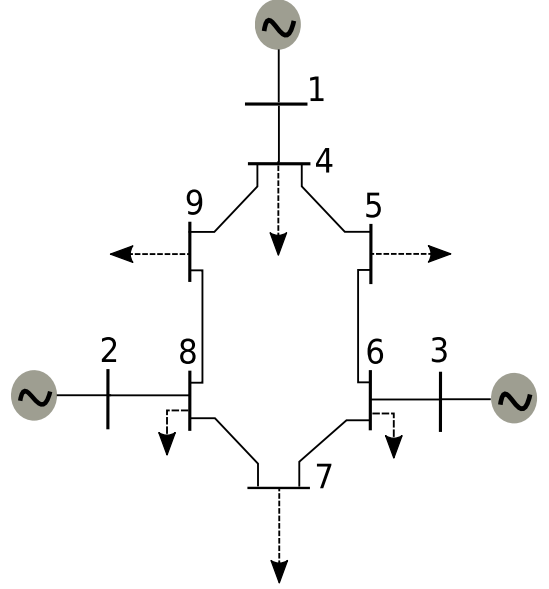

Figure 2: WSCC 3 Machine 9 Bus Power Grid

To use Theorem 8, we will derive a DAE model of the form (4) describing the overall network dynamics (Küstters et al., 2017; Küstters, 2018). Generators connected to bus $i = 1, 2, 3$ are governed by the following differential equations

$$\begin{aligned} \dot{\alpha}^i(t) &= \omega^i(t), \\ M^i \dot{\omega}^i(t) &= -D^i \omega^i(t) + P_g^i(t) - P_e^i(t), \end{aligned}$$

where α^i is the (incremental) angle and ω^i is the angular velocity of the rotor of the i -th generator, P_g^i is the generator power and P_e^i is the electrical power acting on the rotor of the i -th generator; $M_i, D^i \in \mathbb{R}$ are the mass and damping coefficients of the i -th generator, respectively. Assuming that the difference in the rotor angle $\alpha^i(t)$ and the voltage angle $\theta^i(t)$ at the i -th bus stays small, the electrical power acting on the rotor of the i -th generator is given

by:

$$P_e^i(t) = \frac{1}{z_i} (\alpha^i(t) - \theta^i(t)),$$

where $z_i > 0$ is the transient reactance of the generator connected to the i -th bus. Let $P^i(t)$ be the power fed (or extracted out) at the bus i . Also, assume that the difference in voltage angles between two connected bus stays sufficiently small and the line conductances are negligible. Then, the linearized power flow equation at the generator bus $i = 1, 2, 3$ is

$$P^i(t) + P_e^i(t) = \sum_{k=1}^9 w_{ik} (\theta^k(t) - \theta^i(t))$$

and at load bus $i = 4, \dots, 9$ is

$$P^i(t) = \sum_{k=1}^9 w_{ik} (\theta^k(t) - \theta^i(t))$$

where $w_{ik} = -b_{ik} = -b_{ki} \geq 0$, and b_{ik} is the (nonpositive) susceptance between buses i and k . Next let the generator power and power extracted out at the load bus be constant, which allows us to include them as state variables with vanishing derivative. Altogether we obtain for the generator buses $i = 1, 2, 3$ the following DAEs

$$\begin{aligned} E_i \dot{x}_i &= A_i x_i + B_i u_i \\ y_i &= C_i x_i \end{aligned}$$

where $x_i := (P^i, P_g^i, \alpha^i, \omega^i, \theta^i)^\top$ and

$$\begin{aligned} E_i &= \begin{bmatrix} 1 & & & & \\ & 1 & & & \\ & & 1 & & \\ & & & M^i & \\ & & & & 0 \end{bmatrix}, \\ A_i &= \begin{bmatrix} 0 & 0 & 0 & 0 & 0 \\ 0 & 0 & 0 & 0 & 0 \\ 0 & 0 & 0 & 1 & 0 \\ 0 & 1 & -\frac{1}{z_i} & -D^i & \frac{1}{z_i} \\ -1 & 0 & -\frac{1}{z_i} & 0 & \frac{1}{z_i} \end{bmatrix}, \\ B_i &= e_5, \quad C_i = e_5^\top \end{aligned}$$

and for the load buses $i = 4, \dots, 9$, we get

$$\begin{aligned} E_i \dot{x}_i &= A_i x_i + B_i u_i \\ y_i &= C_i x_i \end{aligned}$$

where $x_i = (P^i, \theta^i)^\top$ and

$$E_i = \begin{bmatrix} 1 & 0 \\ 0 & 0 \end{bmatrix}, \quad A_i = \begin{bmatrix} 0 & 0 \\ -1 & 0 \end{bmatrix}, \quad B_i = \begin{bmatrix} 0 \\ 1 \end{bmatrix}, \quad C_i = \begin{bmatrix} 0 & 1 \end{bmatrix},$$

Note that similar as in Example 12 the DAEs corresponding to non-dynamic nodes are modeled by non-regular

DAEs. The coupling equations for all buses are given by power flow equations as follows

$$u_i = \sum_{k=1}^9 w_{ik} (\theta^k - \theta^i).$$

Since, the entire graph is one connected component and it contains three generator buses, the overall DAE is regular (see (Gross et al., 2016)). Thus, we can now use Theorem 8 to obtain possibly indiscernible topological changes in this power network. For that we assume generator parameter values from (Sauer and Pai, 1998) shown in following table.

Bus i	M_i	D_i	z_i
$i = 1$	0.15	0.015	0.14
$i = 2$	0.04	0.008	0.89
$i = 3$	0.02	0.006	1.31

The line impedances are as follows $z_{14} = 0.0576i$, $z_{45} = 0.017 + 0.092i$, $z_{56} = 0.039 + 0.17i$, $z_{67} = 0.0119 + 0.1008i$, $z_{78} = 0.0085 + 0.072i$, $z_{89} = 0.032 + 0.16i$, $z_{94} = 0.01 + 0.085i$, $z_{36} = 0.0586i$, $z_{28} = 0.0625i$, with corresponding line susceptances $b_{ij} := -\frac{\text{im}(z_{ij})}{|z_{ij}|^2}$. Assuming these parameter values we can now form matrices $\mathcal{E} \in \mathbb{R}^{27 \times 27}$ and $\mathcal{A}_{\mathcal{E}} = (\mathcal{A} - \mathcal{B}\mathcal{L}\mathcal{C}) \in \mathbb{R}^{27 \times 27}$ required to form the overall DAE (4).

For this network, there exists an eigenvector $v \in \mathbb{R}^{27}$ corresponding to a zero eigenvalue written as follows:

$$v = [v_1^\top \quad v_2^\top \quad \dots \quad v_9^\top]$$

with

$$\begin{aligned} v_i &= \begin{bmatrix} \frac{1}{z_i} & \frac{-1}{z_i} & 0 & 0 & 1 \end{bmatrix}^\top \text{ for } i = 1, 2, 3 \\ v_i &= \begin{bmatrix} 0 & 1 \end{bmatrix}^\top \text{ for } i = 4, \dots, 9. \end{aligned}$$

For this eigenvector, the condition (9) of Theorem 8 is satisfied for all $1 \leq i, j \leq 9$. Therefore, we conclude that for this specific initial value any topological change is indiscernible. Note that this eigenvector can be written analytically for any network topology and is not restricted to the example under consideration. It corresponds to a situation wherein all buses are operating at same voltage angles resulting in no power flowing between lines; as a consequence, any line changes will not be discernible.

On numerically computing all eigenvectors corresponding to non-zero eigenvalues, we note that condition (9) is not satisfied. Therefore, starting with initial conditions from span of eigenvectors corresponding to non-zero eigenvalues, all topological changes in this network are discernible.

However, it is also important to note that for eigenvectors corresponding to non-zero eigenvalues, condition (9) is ‘‘close’’ to being satisfied for some lines. The non-zero eigenvalues are -0.1381 , $-0.1148 \pm 7.3537i$ and $-0.1162 \pm 6.0873i$. Let us denote an eigenvector corresponding to eigenvalue -0.1381 by $v_1 \in \mathbb{R}^{27}$. Similarly, let $v_2 \in \mathbb{C}^{27}$, its complex conjugate $v_3 \in \mathbb{C}^{27}$, and

$v_4 \in \mathbb{C}^{27}$, its complex conjugate $v_5 \in \mathbb{C}^{27}$, be eigenvectors corresponding to complex conjugate pair of eigenvalues $-0.1304 \pm 7.1067i$ and $-0.1162 \pm 6.0873i$ respectively. For v_1 , we observe that $|(\mathcal{C}v_1)_i - (\mathcal{C}v_1)_j|$ is of the order of magnitude 10^{-4} for any $1 \leq i, j \leq 9, i \neq j$. Thus, it can be said that a line change between any two buses is “close” to being possibly indiscernible. For eigenvectors v_2 and v_3 the quantities $|(\mathcal{C}v_2)_7 - (\mathcal{C}v_2)_8|$ and $|(\mathcal{C}v_3)_7 - (\mathcal{C}v_3)_8|$ are also of the order of magnitude 10^{-4} ; thus, disconnecting line (7, 8) is “close” to being possible indiscernible. Lastly, for eigenvectors v_4 and v_5 too, the quantities $|(\mathcal{C}v_4)_4 - (\mathcal{C}v_4)_5|$ and $|(\mathcal{C}v_5)_4 - (\mathcal{C}v_5)_5|$ are of the order of magnitude 10^{-4} ; therefore, disconnecting line (4, 5) is also “close” to being possible indiscernible. It is clear that the discernibility of changes in links will depend upon the precision with which the output at each node is being measured. Thus, the notion of “degree” of discernibility, considered in (Baglietto et al. (2014)) for classical ODEs, becomes relevant. However, an investigation of this point in the context of DAE networks is a subject of future research.

5. Indiscernibility for homogeneous networks

For homogenous networks, it is possible to simplify the result further. In this case, we have identical differential equations connected by a graph $\mathfrak{G} = (\mathfrak{V}, \mathfrak{E})$ with weighted Laplacian \mathfrak{L} . Substituting $E_i = E, A_i = A, B_i = B, C_i = C$ and $n_i = \bar{n}$ for all $i \in \mathfrak{V}$ in (4), we are able to write the overall dynamics in a simplified form as follows.

$$\mathcal{E}\dot{x} = \mathcal{A}_{\mathfrak{L}}x, \quad (12)$$

where

$$\begin{aligned} \mathcal{E} &:= (I_N \otimes E), \\ \mathcal{A}_{\mathfrak{L}} &:= (I_N \otimes A) - \mathfrak{L} \otimes BC. \end{aligned}$$

As a result, indiscernibility of homogenous DAE network can be partly described in terms of the eigenvectors of the Laplacian of the connection graph under certain observability assumptions. For that we first note the following properties of eigenvalue-eigenvectors pairs of $(\mathcal{E}, \mathcal{A}_{\mathfrak{L}})$ in the homogeneous case.

Lemma 13. Let $\alpha_1, \alpha_2, \dots, \alpha_N \in \mathbb{R}$ be the N real eigenvalues (counting multiples) of the symmetric Laplacian \mathfrak{L} . Then, for $(\mathcal{E}, \mathcal{A}_{\mathfrak{L}})$ as above,

$$\text{spec}(\mathcal{E}, \mathcal{A}_{\mathfrak{L}}) = \bigcup_{i=1}^N \text{spec}(E, A - \alpha_i BC). \quad (13)$$

Furthermore, for all eigenvalues α of \mathfrak{L} , all corresponding eigenvectors z^α and any eigenvector chain $(w_1^\alpha, \dots, w_k^\alpha)$ of $(E, A - \alpha BC)$ we have that (v_1, \dots, v_k) is an eigenvector chain of $(\mathcal{E}, \mathcal{A}_{\mathfrak{L}})$, where

$$v_i = z^\alpha \otimes w_i^\alpha, \quad i = 1, \dots, k. \quad (14)$$

Conversely, all generalized eigenspaces of $(\mathcal{E}, \mathcal{A}_{\mathfrak{L}})$ are spanned by vectors of the form (14).

Proof. Since \mathfrak{L} is symmetric there exists an orthogonal coordinate transformation S such that $S^\top \mathfrak{L} S = \Lambda = \text{diag}\{\alpha_1, \dots, \alpha_N\}$. Choose a coordinate transformation $D := S \otimes I_{\bar{n}}$ for $\mathcal{A}_{\mathfrak{L}}$. From the properties of the Kronecker product $(X \otimes Y)^\top = X^\top \otimes Y^\top$ and $(X \otimes Y)(Z \otimes W) = (XZ \otimes YW)$ it follows that

$$\begin{aligned} D^\top \mathcal{A} D &= D^\top (I_N \otimes A) D \\ &= (S^\top \otimes I_{\bar{n}})(I_N \otimes A)(S \otimes I_{\bar{n}}) \\ &= (S^\top \otimes I_{\bar{n}})(S \otimes A) = I_N \otimes A = \mathcal{A}, \\ D^\top \mathcal{E} D &= \mathcal{E} \end{aligned}$$

and

$$\begin{aligned} D^\top (\mathfrak{L} \otimes BC) D &= (S^\top \otimes I_{\bar{n}})(\mathfrak{L} \otimes BC)(S \otimes I_{\bar{n}}) \\ &= \Lambda \otimes BC. \end{aligned}$$

Therefore,

$$\begin{aligned} D^\top \mathcal{A}_{\mathfrak{L}} D &= D^\top \mathcal{A} D - D^\top (\mathfrak{L} \otimes BC) D \\ &= (I_N \otimes A) - (\Lambda \otimes BC) \\ &= \text{diag}\{A - \alpha_1 BC, A - \alpha_2 BC, \dots, A - \alpha_N BC\}, \end{aligned}$$

which shows (13).

Note that for any eigenvalue-eigenvector pair $(\alpha, z^\alpha) \in \mathbb{R} \times \mathbb{R}^N$ of \mathfrak{L} and any $(\lambda, w) \in \mathbb{C} \times \mathbb{C}^{\bar{n}}$ we have

$$\begin{aligned} (\mathcal{A}_{\mathfrak{L}} - \lambda \mathcal{E})(z^\alpha \otimes w) &= ((I_N \otimes A) - (\mathfrak{L} \otimes BC))(z^\alpha \otimes w) - \lambda(z^\alpha \otimes Ew) \\ &= (z^\alpha \otimes Aw) - (\mathfrak{L}z^\alpha \otimes BCw) - \lambda(z^\alpha \otimes Ew) \\ &= (z^\alpha \otimes Aw) - (\alpha z^\alpha \otimes BCw) - \lambda(z^\alpha \otimes Ew) \\ &= z^\alpha \otimes ((A - \alpha BC - \lambda E)w) \end{aligned} \quad (15)$$

as well as $\mathcal{E}(z^\alpha \otimes w) = z^\alpha \otimes Ew$. This shows that (14) indeed leads to an eigenvector chain as claimed.

Finally, the block diagonal structure obtained after applying the coordinate transformation D implies that for each eigenvalue λ of $(\mathcal{E}, \mathcal{A}_{\mathfrak{L}})$ the corresponding generalized eigenspace \mathcal{V}_λ is composed of a direct sum of the generalized eigenspaces $\mathcal{V}_\lambda^\alpha$ of $(E, A - \alpha BC)$. The latter is spanned by eigenvector chains and the construction (14) leaves linear independents intact, so that the eigenvector chains constructed by (14) indeed span \mathcal{V}_λ . \square

Similar as in the homogeneous case we can now utilize Lemma 7 to simplify the condition for the existence of indiscernible initial states.

Corollary 14. Consider a family of identical DAEs (1) of the form

$$\begin{aligned} E\dot{x} &= Ax + Bu \\ y &= Cx \end{aligned}$$

connected via the diffusive coupling (2) by a network with weighted Laplacian \mathfrak{L} resulting in the overall system (12), which we assume to be regular. Then any $v \in \mathbb{R}^n$ is an

indiscernible initial state for the removal/change/addition of edge (i, j) if it has the form

$$v = z \otimes w$$

where $z \in \mathbb{R}^N \setminus \{0\}$ is an eigenvector of \mathfrak{L} for eigenvalue α and $w \in \mathbb{R}^n \setminus \{0\}$ is an eigenvector of $(E, A - \alpha BC)$ such that either

$$z_i = z_j \quad (16a)$$

or

$$BCw = 0. \quad (16b)$$

Proof. Let $\bar{\mathfrak{L}}$ the Laplacian resulting from the change of edge (i, j) . Then by Theorem 4 it suffices to show that v is a common eigenvector of $(\mathcal{E}, \mathcal{A}_{\mathfrak{L}})$ and $(\mathcal{E}, \mathcal{A}_{\bar{\mathfrak{L}}})$. From Lemma 13 it follows that v is indeed an eigenvector of $(\mathcal{E}, \mathcal{A}_{\mathfrak{L}})$ and by Lemma 7 v is also an eigenvector of $(\mathcal{E}, \mathcal{A}_{\bar{\mathfrak{L}}})$ if, and only if $(\mathcal{A}_{\mathfrak{L}} - \mathcal{A}_{\bar{\mathfrak{L}}})v = 0$. Due to the special structure of v this can be rewritten as

$$(\mathfrak{L} - \bar{\mathfrak{L}})z \otimes BCw = 0.$$

This is clearly satisfied if either $z_i = z_j$ (because $\mathfrak{L} - \bar{\mathfrak{L}} = \gamma(e_i - e_j)(e_i - e_j)^\top$ for some $\gamma \in \mathbb{R}$) or $BCw = 0$. \square

We note following aspects of the conditions obtained in Corollary 14.

1. First note that the two conditions in (16) have a very distinct feature which is as follows. The condition $z_i = z_j$ only depends on the Laplacian of network graph. On the other hand existence of eigenvector w of the pair $(E, A - \alpha BC)$ for which $BCw = 0$ is equivalent the existence of an eigenvector w of (E, A) with $BCw = 0$ which in turn is solely a property of the individual subsystems. Thus, Corollary 14 offers two independent indiscernibility conditions – one on the network and the other one on each subsystem.

2. The fact, that existence of an eigenvector w of the pair (E, A) for which $BCw = 0$ leads to indiscernibility, is quite intuitive because of the following reason. If we set the initial condition of each subsystem to be in the span of w , then the diffusive coupling between any two nodes will be annihilated by the matrix B . Thus, it will not have any effect on the overall dynamics and hence addition/removal of any edge (i, j) will be unnoticed.

3. The Laplacian matrix \mathfrak{L} always has at least one eigenvalue which is zero with corresponding eigenvector $z = (1, 1, \dots, 1)^\top$. The condition $z_i = z_j$ is always satisfied for this eigenvector. As a consequence, any topological change of a homogeneous network is necessarily possibly-indiscernible. This special eigenvector corresponds to the situation where all subsystems start with the same initial value; as a consequence, the diffusive coupling is zero and a topological variation has no effect on the dynamics.

4. If we assume that the matrix B is full column rank and that the individual systems are observable in the behavioral sense², i.e. $\begin{bmatrix} \lambda E - A \\ C \end{bmatrix}$ has full rank for all $\lambda \in \mathbb{C}$

then condition (16b) is never satisfiable.

Remark 15. Both Theorem 8 and Corollary 14 rest on the computation of certain eigenspaces. In addition to the fact that this computation can be performed off-line (cf. Remark 9), it is also worth mentioning that computationally efficient algorithms do exist to approach large-scale eigenvalue problems, e.g. see Saad (1992). Moreover, for several fundamental graphs such as complete, star and grid graphs an analytical characterization of the eigenspaces is available (Mesbahi and Egerstedt, 2010, Section 2.4). This characterization can be used in connection with Corollary 14 to check condition (16a) without resorting to any numerical computation.

6. Regularity preserving topological changes

Our main results (Theorems 4 and 8) assume regularity preserving topological changes. Without the regularity assumption, uniqueness of solutions does not hold any more, so that even Definition 1 becomes meaningless. In general, it is not a trivial task to decide whether the overall DAE (4) is regular or not. The following examples show that it is possible that although all subsystems are regular, the coupled system loses regularity; and, on the other hand, the coupled system can be regular although the individual subsystems are not regular.

Example 16 (Loss of regularity by coupling³). Consider two DAE systems given by

$$\begin{aligned} 0 &= x_1 + u_1, & 0 &= x_2 + u_2, \\ y_2 &= x_1, & y_2 &= x_2, \end{aligned}$$

which are clearly regular. However, under diffusive coupling with coupling strength $w_{12} = w_{21} = \frac{1}{2}$, the overall system reads as

$$\begin{aligned} 0 &= \frac{1}{2}x_1 + \frac{1}{2}x_2, \\ 0 &= \frac{1}{2}x_1 + \frac{1}{2}x_2, \end{aligned}$$

which is *not regular*.

Example 17 (Regularization by coupling). Consider the following three DAE systems

$$\begin{aligned} 0 &= x_1, & 0 &= x_2, & 0 &= u_3 \\ y_1 &= x_1, & y_2 &= x_2, & y_3 &= x_3 \end{aligned}$$

where the third DAE is not regular (because $E_3 = 0 = A_3$). However, under diffusive coupling with $w_{12} = w_{21} = 0$, $w_{13} = w_{31} = R_1 > 0$, and $w_{23} = w_{32} = R_2 > 0$, the overall DAE reads as

$$\begin{aligned} 0 &= x_1 \\ 0 &= x_2 \\ 0 &= (R_1 + R_2)x_3 - R_1x_1 - R_2x_2 \end{aligned}$$

which is regular, for any positive choices of R_1 and R_2 . Another example is the Wheatstone bridge as in Example 12 above.

²see e.g. Berger et al. (2017)

³We thank Ferdinand Küsters for providing this nice example.

Under the (reasonable) assumption that the nominal coupled DAE $(\mathcal{E}, \mathcal{A}_{\mathcal{L}})$ is regular, one can interpret any topological change $\mathcal{L} \rightarrow \bar{\mathcal{L}}$ as an introduction of an additional feedback term:

$$\mathcal{A}_{\bar{\mathcal{L}}} = \mathcal{A}_{\mathcal{L}} \pm \underbrace{\mathcal{B}((\bar{\mathcal{L}} - \mathcal{L}) \otimes I_p)}_{:=\mathcal{F}}\mathcal{C}.$$

Therefore, we can use the following sufficient condition for regularity:

Lemma 18 ((Bunse-Gerstner et al., 1992, Thm. 11)). Consider a regular matrix pair $(E, A) \in \mathbb{R}^{n \times n} \times \mathbb{R}^{n \times n}$ and $B \in \mathbb{R}^{n \times p}$. If

$$\text{rank } E = \text{rank}[E, B],$$

then $(E, A + BF)$ is regular for all feedback matrices $F \in \mathbb{R}^{p \times n}$.

Therefore, we arrive immediately at the following sufficient condition for regularity preservation:

Corollary 19. Consider a regular coupled DAE (4). If $\text{rank } \mathcal{E} = \text{rank}[\mathcal{E}, \mathcal{B}]$ then any topological change $\mathcal{L} \rightarrow \bar{\mathcal{L}}$ is regularity preserving.

Due to the block structure of \mathcal{E} and \mathcal{B} , the condition $\text{rank } \mathcal{E} = \text{rank}[\mathcal{E}, \mathcal{B}]$ is equivalent to $\text{rank } E_i = \text{rank}[E_i, B_i]$ for all $i = 1, 2, \dots, N$. In fact, by considering a removal/addition/change of a single edge (i, j) the regularity-preservation condition reduces in view of (10) to the two sufficient conditions

$$\text{rank } E_i = \text{rank}[E_i, B_i] \quad \text{and} \quad \text{rank } E_j = \text{rank}[E_j, B_j].$$

In other words, any topological change involving edges between nodes which satisfy the rank condition $\text{rank } E_i = \text{rank}[E_i, B_i]$ preserves regularity of the corresponding DAE.

7. Conclusions

Understanding when a topological variation cannot be detected is fundamental for monitoring, and eventually controlling, complex networks. In this paper, we have studied this problem for a class of linear DAE networks, using tools from control theory. The results, which account for multivariable and heterogeneous dynamics, show that the problem can be fully characterized in terms of generalized eigenspaces. Moreover, under rather mild conditions, the existence of indiscernible topological changes can be assessed by only looking at the properties of the nominal network configuration.

Our results represent only a first step towards the development of algorithms for detecting and isolating network topological changes. Yet, the results provide many quantitative insights into the problem. For example, they indicate that under the homogeneity assumption, one can

obtain separate conditions on the dynamics at the nodes and the network structure, in which case assessing discernibility is not more difficult than for a simple integrator network Battistelli and Tesi (2015).

We envision three main directions for future research, all of major practical value. The present results establish fundamental limitations to the problem of detecting topological changes from measurements, that is limitations which hold irrespective of the specific detection algorithm (detector) one is willing to use, even in the most favourable situation where the whole network state is available for measurements. The design of detectors clearly remains an important research line. In this respect, we point out that, in addition to the research works mentioned in the Introduction, the problem of designing detectors has been also considered from a control-theoretic perspective within the context of switched systems (Vidal et al., 2002; Babaali and Egerstedt, 2004; Baglietto et al., 2007; De Santis, 2011; Baglietto et al., 2014). While these results only consider ODE systems and do not address the network case, they capture the switching nature of the topology detection problem and also consider settings where a switching should be detected only via a limited number of sensors, which is always the case in practice when dealing with networks. As such, these results may prove relevant for the problem discussed in this paper.

Second, extending the analysis so as to incorporate a notion of “degree” of discernibility, as done in Baglietto et al. (2014). In fact, it is natural to expect that states close (in terms of Euclidean distance) to the indiscernibility set are in practice as much critical as indiscernible states. A notion of “degree” of discernibility would then help us to identify regions of the state space where detecting topological changes is more easy or difficult to obtain.

A third research line pertains how to “design” the network structure and its weights in order to decrease, and possibly minimize, the set of undetectable topological variations. Interesting results in this direction have been reported in Shafi et al. (2012), where the authors consider the problem of assigning edge weights to enforce constraints on the Laplacian spectrum. While these results can be used in connection with Corollary 14, it remains unclear how they can be extended to the general setting of Theorem 8 where the conditions for discernibility depend on the coupling between the node dynamics and the graph structure. Moreover, it is also unclear how one could translate regularity-type constraints (Section 6) into a design procedure as the one in Shafi et al. (2012).

8. References

- Angulo, M., Moreno, J., Lippner, G., Barabási, A., Liu, Y., 2017. Fundamental limitations of network reconstruction from temporal data. *Journal of The Royal Society Interface* 14.
- Arcak, M., 2007. Passivity as a design tool for group coordination. *IEEE Trans. Autom. Control* 52, 1380–1390.

- Babaali, M., Egerstedt, M., 2004. Observability of switched linear systems. In: *Hybrid Systems: Computation and Control*. Vol. 2993 of *Lecture Notes in Computer Science*. Springer, pp. 48–63.
- Baglietto, M., Battistelli, G., Scardovi, L., 2007. Active mode observability of switching linear systems. *Automatica* 43 (8), 1442–1449.
- Baglietto, M., Battistelli, G., Tesi, P., 2014. Mode-observability degree in discrete-time switching linear systems. *Syst. Control Lett.* 70, 69–76.
- Bai, H., Arcak, M., Wen, J., 2011. *Cooperative control design: a systematic, passivity-based approach*. Springer Science & Business Media.
- Banavar, J., Colaiori, F., Flammini, A., Maritan, A., Rinaldo, A., 2000. Topology of the fittest transportation network. *Physical Review Letters* 84, 4745–4748.
- Baroah, P., 2008. Distributed cut detection in sensor networks. In: *Proc. 47th IEEE Conf. Decis. Control*, Cancun, Mexico. pp. 1097–1102.
- Battistelli, G., Tesi, P., 2015. Detecting topology variations in dynamical networks. In: *Proc. 54th IEEE Conf. Decis. Control*, Osaka, Japan. IEEE, pp. 3349–3354.
- Battistelli, G., Tesi, P., 2017. Detecting topology variations in networks of linear dynamical systems. *IEEE Trans. Control Network Systems* In press.
- Beard, R. W., McLain, T. W., Nelson, D. B., Kingston, D., Johanson, D., 2006. Decentralized cooperative aerial surveillance using fixed-wing miniature UAVs. *Proc. of the IEEE* 94, 1306–1324.
- Berger, T., Ilchmann, A., Trenn, S., 2012. The quasi-Weierstraß form for regular matrix pencils. *Linear Algebra Appl.* 436 (10), 4052–4069.
- Berger, T., Reis, T., Trenn, S., 2017. Observability of linear differential-algebraic systems: A survey. In: Ilchmann, A., Reis, T. (Eds.), *Surveys in Differential-Algebraic Equations IV*. *Differential-Algebraic Equations Forum*. Springer-Verlag, Berlin-Heidelberg, pp. 161–219.
- Bunse-Gerstner, A., Mehrmann, V., Nichols, N. K., 1992. Regularization of descriptor systems by derivative and proportional state feedback. *SIAM J. Matrix Anal. & Appl.* 13 (1), 46–67.
- Cavvaro, G., Arghandeh, R., Barchi, G., von Meier, A., 2015. Distribution network topology detection with time-series measurements. In: *Innovative Smart Grid Technologies Conference (ISGT), 2015 IEEE Power & Energy Society*. IEEE, pp. 1–5.
- Chakraborty, A., Khargonekar, P., 2013. Introduction to wide-area control of power systems. In: *Proc. American Control Conf. 2013*. Washington, DC, USA, pp. 6758–6770.
- Chowdhary, G., Egerstedt, M., Johnson, E. N., 2011. Network discovery: An estimation based approach. In: *Proc. American Control Conf. 2011*. San Francisco, USA, pp. 1076–1081.
- Costanzo, J., Materassi, D., Sinopoli, B., 2017. Using Viterbi and Kalman to detect topological changes in dynamic networks. In: *Proc. American Control Conf. 2017*. Seattle, WA, USA, pp. 5410–5415.
- De Santis, E., 2011. On location observability notions for switching systems. *Syst. Control Lett.* 60 (10), 807–814.
- Dhal, R., Torres, J., Roy, S., 2013. Link-failure detection in network synchronization processes. In: *IEEE Global Conference on Signal and Information Processing (GlobalSIP)*. pp. 779–782.
- Gross, T. B., Trenn, S., Wirsén, A., 2016. Solvability and stability of a power system DAE model. *Syst. Control Lett.* 29, 12–17.
- Küstners, F., 2018. Switch observability for differential-algebraic systems. Ph.D. thesis, Department of Mathematics, University of Kaiserslautern.
- Küstners, F., Patil, D., Tesi, P., Trenn, S., 2017. Indiscernible topological variations in DAE networks with applications to power grids. In: *Proc. of the 20th IFAC World Congress*, Toulouse, France. pp. 7333–7338, *IFAC-PapersOnLine* 50 (1).
- Mesbahi, M., Egerstedt, M., 2010. *Graph Theoretic Methods in Multi-agent Networks*. Princeton University Press.
- Nabavi, S., Chakraborty, A., 2016. A graph-theoretic condition for global identifiability of weighted consensus networks. *IEEE Trans. Autom. Control* 61, 497–502.
- Ögren, P., Fiorelli, E., Leonard, N., 2004. Cooperative control of mobile sensor networks: Adaptive gradient climbing in a distributed network. *IEEE Trans. Autom. Control* 49, 1292–1302.
- Rahimian, M. A., Ajorlou, A., Aghdam, A. G., 2012. Characterization of link failures in multi-agent systems under the agreement protocol. In: *Proc. American Control Conf. 2012*. Montréal, Canada.
- Rahimian, M. A., Preciado, V. M., 2015. Detection and isolation of failures in directed networks of lti systems. *IEEE Trans. Control Network Systems* 2 (2), 183–192.
- Saad, Y., 1992. *Numerical methods for large eigenvalue problems*. Manchester University Press.
- Sanandaji, B. M., Vincent, T. L., Wakin, M. B., 2011. Exact topology identification of large-scale interconnected dynamical systems from compressive observations. In: *Proc. American Control Conf. 2011*. San Francisco, CA, USA, pp. 649–656.
- Sauer, P., Pai, M., 1998. *Power System Dynamics and Stability*. Prentice Hall.
URL <https://books.google.co.in/books?id=d00eAQAAIAAJ>
- Shafi, S. Y., Arcak, M., Ghaoui, L. E., July 2012. Graph weight allocation to meet laplacian spectral constraints. *IEEE Trans. Autom. Control* 57 (7), 1872–1877.
- Timme, M., 2007. Revealing network connectivity from response dynamics. *Physical Review Letters* 98, 224101.
- Torres, J. A., Dhal, R., Roy, S., 2015. Detecting link failures in complex network processes using remote monitoring. In: *Proc. American Control Conf. 2015*. Chicago, USA.
- Vidal, R., Chiuso, A., Sastry, S. S., 2002. Observability and identifiability of jump linear systems. In: *Proc. 41st IEEE Conf. Decis. Control*. pp. 3614–3619.
- Zhu, H., Giannakis, G. B., 2012. Sparse overcomplete representations for efficient identification of power line outages. *ieetps* 27 (4), 2215–2224.
- Zimmerman, R. D., Murillo-Sanchez, C. E., Thomas, R. J., Feb 2011. *Matpower: Steady-state operations, planning, and analysis tools for power systems research and education* 26 (1), 12–19.