

The bang-bang funnel controller for uncertain nonlinear systems with arbitrary relative degree

Daniel Liberzon and Stephan Trenn

Abstract—The paper considers output tracking control of uncertain nonlinear systems with arbitrary known relative degree and known sign of the high frequency gain. The tracking objective is formulated in terms of a time-varying bound—a funnel—around a given reference signal. The proposed controller is bang-bang with two control values. The controller switching logic handles arbitrarily high relative degree in an inductive manner with the help of auxiliary derivative funnels. We formulate a set of feasibility assumptions under which the controller maintains the tracking error within the funnel. Furthermore, we prove that under mild additional assumptions the considered system class satisfies these feasibility assumptions if the selected control values are sufficiently large in magnitude. Finally, we study the effect of time delays in the feedback loop and we are able to show that also in this case the proposed bang-bang funnel controller works under slightly adjusted feasibility assumptions.

I. INTRODUCTION

Is it possible to design a controller which only uses *two values*, “bang-bang”, such that the output of an uncertain system tracks an arbitrary reference signal with a prespecified strict error bound guaranteeing a desired *transient response* as well as a desired *arbitrary tracking accuracy*? The surprising answer to this question is: Yes, provided the system in question has a known relative degree $r \in \mathbb{N}$ and the two input values are large enough.

Our main contribution is therefore the presentation of a new controller design—the bang-bang¹ funnel controller—which is able to achieve the above objectives while remaining *simple to implement* even for high relative degree systems. In particular, we are “overcoming the obstacle of high relative degree” [16] with a simple and intuitive controller.

The above question without the bang-bang assumption was already posed and answered in 1991 by Miller and Davison [15] for linear systems with arbitrary relative degree but the prespecified error bounds were piecewise-constant with two values only. The same affirmative answer for a more general prespecified error bound, the *funnel*, was obtained by Ilchmann et al. [7] where only the relative degree one case

was considered but the system class encompassed nonlinear systems, modeled with functional differential equations, including hysteresis effects and delays. The so-called funnel controller was later successfully applied to systems with higher relative degree [8] using a “backstepping” procedure. In the latter work a nice review is given on known controller designs for systems with high relative degree, see also [16] which discusses the “obstacles of high relative degree” for adaptive control problems in general. The funnel controller was also studied with respect to input constraints, first for a model of chemical reactors [9] and later for the general case [5], [6]. These works only considered the relative degree one case and only recently it was possible to construct a funnel controller with input saturations for the relative degree two case [3]. The latter paper used the new approach to introduce a funnel also for the derivative of the error and strongly inspired our first work [12] on the bang-bang funnel controller which considers relative degree one and two, but the controller design in [12] is completely different from the one in [3]. The current paper extends our results in [12] to arbitrary relative degree without high “costs” on the design. In fact, as shown in Figure 2 our switching logic consists of r basically identical, simple blocks, where $r \in \mathbb{N}$ is the relative degree. This is a major advantage over other methods like backstepping where high implementation costs occur when the relative degree is high.

The approach taken here is similar to sliding-mode control [18] and there are sliding mode controllers available for arbitrary high relative degree [11]. However, in contrast to sliding mode control, the bang-bang funnel controller explicitly defines (time-varying) error bounds and is therefore also able to guarantee desired transient behavior whereas sliding mode control only specifies the desired sliding surface without any additional prespecified error bounds. Furthermore, sliding mode control by design has the problem of implementation as the exact sliding on the desired surface only appears in theory; for any practical implementation some measure must be taken to prevent chattering. The design of the bang-bang funnel controller is such that it can readily be implemented and chattering does not occur.

The bang-bang funnel controller also shares many features with event-based controllers [1], in particular, a control action (change from $u = U_+$ to $u = U_-$ or vice versa) only takes place when necessary (i.e. when the error signal approaches the corresponding funnel boundary). However, we are not aware of any event based control scheme capable of achieving reference tracking with prespecified error accuracy for an unknown nonlinear system with arbitrary relative degree.

Altogether the bang-bang funnel controller has the following

This work was supported by the NSF grants CNS-1217811 and ECCS-1231196 and by a National Research Foundation Grant funded by the Korean Government (NRF-2011-220-D00043)

D. Liberzon is with the Coordinated Science Laboratory, University of Illinois at Urbana-Champaign, Urbana, IL 61801, USA; S. Trenn is with the Department of Mathematics, University of Kaiserslautern, 67663 Kaiserslautern, Germany
email: trenn@mathematik.uni-kl.de

¹Here by “bang-bang-control” we mean the case that the controller produces a scalar piecewise-constant input signal which can only attain two values $U^- \in \mathbb{R}$ and $U^+ \in \mathbb{R}$ with $U^- < U^+$; in most cases it actually holds that $U^- < 0 < U^+$ although our theory does not need the latter assumption in general.

advantages and motivations:

- (i) In a digitally connected systems framework the communication from the controller to the system only needs one bit and this bit is only sent when necessary.
- (ii) The control action might in reality only consist of “On” and “Off” and our controller does take this into account explicitly (no pulse-width modulation or similar techniques are needed); see also the recent work on discrete-valued control, e.g. [19].
- (iii) Using the maximal possible input values yields faster “convergence” compared to using the continuous funnel controller with input constraints (in general, a time optimal control is often bang-bang).
- (iv) Due to time delays and hysteresis effects the implementation of simple sliding mode controller [18] usually results in a bang-bang controller; however, the resulting switching signal is often only given implicitly and is not designed explicitly. In contrast to sliding mode control, we start our theoretical analysis directly from a switching rule with locally finite switchings.
- (v) In some areas (e.g. power electronics) it is common to use so-called averaging methods (for a recent overview see e.g. [17]), i.e. a binary input signal is switched very fast with a certain ratio of the two values. For the analysis it is then assumed that the input is actually the continuous value determined by this ratio; our approach allows for a direct analysis of the systems behavior for a binary input signal.
- (vi) Almost all controllers are now implemented digitally; a bang-bang approach (or a controller with only a finite set of possible values) is therefore a much more natural approach.
- (vii) In contrast to continuous controllers the implementation of a bang-bang controller is much simpler in general because it suffices to implement a simple finite automaton, whereas a classical continuous controller might need to carry out complex mathematics like (numerically) solving differential equations in real time.

Clearly, using a bang-bang control is not always desirable, e.g. when fast changes of the input values are not physically possible. Furthermore, of course “there is no such thing as a free lunch”, i.e. rather strong control objectives come with a price: The input values might be *very large*, the time difference between consecutive switches of the input values might be *very small* and the proposed controller will need the measurement of the first $r - 1$ derivatives of the error, which might be in reality *not available for measuring*. However, we see our main contribution in providing a proof-of-concept for a new controller design; an application to real world problems might need further adjustments which are not in the main scope of this paper. Therefore, a large part of this paper is devoted to the precise definition of the controller and detailed proofs of the theoretical results which also give an intuition why the controller works. Our main results are not only “existence” results because we also formulate “feasibility assumptions” which can be checked provided that at least some bounds on the systems dynamics are known and which, if satisfied,

guarantee that our proposed controller works as desired.

The paper is organized as follows. We start by presenting a formal problem description in Section II and detail which structural assumption we make. The switching logic is defined afterwards in Section III. After the formal definition of the switching logic we already formulate in Section III-C an important consequence of our forthcoming main results, namely that under rather mild assumptions the bang-bang funnel controller works provided the input values $U^+ > 0$ and $U^- < 0$ are large enough. Our main result, Theorem 4.1, is formulated in Section IV after the feasibility assumptions are formulated and briefly explained. With the help of Theorem 4.2 we show that the feasibility assumptions are not contradictory and present a constructive procedure how to construct feasible funnels and controller parameters. Since the closed loop is a hybrid system, some effort must be taken to show that the system in closed loop with the bang-bang funnel controller is well posed, i.e. the existence of local solutions must be shown. This is done with the help of Theorem 5.3 in Section V. The proof of the main result is carried out in Section VI and uses an inductive argument to prove the result for arbitrary relative degree. In Section VII we briefly discuss the possibilities of time delays in the feedback loop and show that the bang-bang funnel controller can tolerate them; the allowed size of the time delays can again be checked with the help of feasibility assumptions. Finally, we carry out simulation for a relative degree four example in the Section VIII.

Throughout this paper we use the following notation. The (Euclidian) norm of $x \in \mathbb{R}^n$ is denoted with $|x|$. For defining predicates (i.e. functions with values in the set $\{\text{true}, \text{false}\}$) we use the notation $[statement] \in \{\text{true}, \text{false}\}$; the negation of a boolean variable b is denoted by $\neg b$. For a function $f : \mathbb{R} \rightarrow \mathbb{R}$ and an interval $I \subseteq \mathbb{R}$ we denote with $f_I : \mathbb{R} \rightarrow \mathbb{R}$ the truncation of f to the interval I given by $f_I(x) = f(x)$ for all $x \in I$ and $f_I(x) = 0$ otherwise. With $\mathcal{C}^k(X \rightarrow Y)$, or short \mathcal{C}^k , we denote the set of all k -times continuously differentiable functions $f : X \rightarrow Y$; \mathcal{C}_{pw}^k denotes piecewise k -times continuously differentiable functions (not necessarily continuous). For a piecewise-continuous function f and $t \in \mathbb{R}$ let $f(t-) := \lim_{\varepsilon \searrow 0} f(t - \varepsilon)$. With $\mathcal{L}^\infty(X \rightarrow Y)$ we denote the set of all measurable and essentially bounded functions $f : X \rightarrow Y$ with the supremum norm $\|f\|_\infty$. The set $\mathcal{W}^{k,\infty}(X \rightarrow Y)$ denotes the set of all functions $f : X \rightarrow Y$ with absolutely continuous $(k - 1)$ -th derivative and right-continuous k -th derivative and, additionally, $f^{(i)} \in \mathcal{L}^\infty(X \rightarrow Y)$ for all $i = 0, 1, \dots, k$. Throughout this work $n \in \mathbb{N}$ denotes the state dimension of the system and $r \in \mathbb{N}$ with $1 \leq r \leq n$ is the relative degree as defined in Section II-B.

II. PROBLEM FORMULATION AND STRUCTURAL ASSUMPTIONS

A. Overall system structure and control objectives

We consider SISO systems described by a nonlinear differential equation

$$\begin{aligned} \dot{x} &= F(x) + G(x)u, & x(0) &= x^0 \in \mathbb{R}^n \\ y &= H(x) \end{aligned} \tag{1}$$

with known relative degree r and positive “high frequency” gain (see the following Section II-B for details). System (1) is uncertain in the sense that we don’t have exact knowledge of F , G and H (for example the system description might contain numerous unknown parameters). Our aim is to develop a bang-bang funnel controller by a feedback mechanism as shown in Figure 1a which ensures *approximate tracking* of a reference signal $y_{\text{ref}} : \mathbb{R}_{\geq 0} \rightarrow \mathbb{R}$.

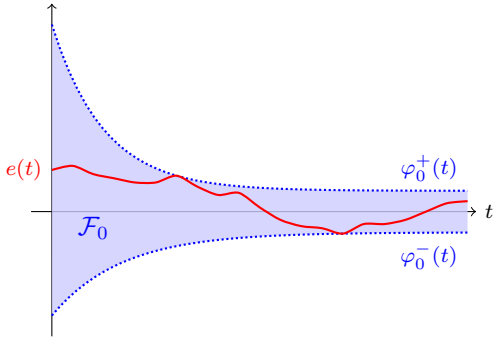
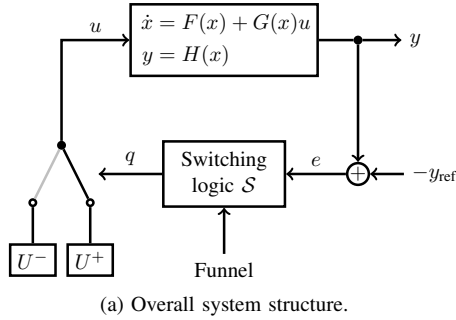

Fig. 1: The overall setup for the bang-bang funnel controller.

In fact, we want to ensure that the error

$$e := y - y_{\text{ref}} \quad (2)$$

meets prespecified (time-varying) error bounds which are given by the funnel

$$\mathcal{F}_0 := \{ (t, e) \in \mathbb{R}_{\geq 0} \times \mathbb{R} \mid \varphi_0^-(t) \leq e \leq \varphi_0^+(t) \}, \quad (3)$$

where $\varphi_0^-, \varphi_0^+ : \mathbb{R}_{\geq 0} \rightarrow \mathbb{R}$ are the prespecified (time-varying) error bounds, see also Figure 1b. Note that by saying “the error evolves within the funnel” we formally mean $(t, e(t)) \in \mathcal{F}_0$ for all $t \geq 0$.

We use the index 0 for the funnel because we will also consider funnels \mathcal{F}_i , $i = 1, \dots, r-1$ for the i -th derivative $e^{(i)}$ of e . In particular, the switching logic is allowed to take derivatives of the error signal e , but otherwise it has, apart from the relative degree, no knowledge of the system (1). However, to meet the desired error bounds the system must fulfill certain feasibility assumptions, which can only be checked when certain bounds on the system dynamics are known.

The most important property of the system class considered here is an instantaneous input-output property that can be

paraphrased as follows for any $t \geq 0$:

$$\begin{aligned} u(t) \gg 0 &\Rightarrow y^{(r)}(t) \gg 0, \\ u(t) \ll 0 &\Rightarrow y^{(r)}(t) \ll 0, \end{aligned} \quad (4)$$

and follows from the structural assumption (\mathbf{F}_1) below. Apart from some boundedness conditions, nothing more is needed to prove our main result. In fact, it is actually possible to even further broaden the system class considered, e.g. by including functional differential equation like hysteresis effects and time delays as was done in [7]. However, we do not use this most general setup in order to avoid technicalities and also to focus more on the switching logic.

B. Structural assumptions on the system class and the reference signal

Throughout this work we assume that system (1) has known relative degree $r \in \mathbb{N}$ with positive gain, i.e. we make the following structural assumption.

(\mathbf{F}_1) There exists a coordinate transformation (a diffeomorphism) $x \mapsto (Y^{r-1}, z^\top)^\top$, $Y^{r-1} := (y, \dot{y}, \dots, y^{(r-1)})$, which transforms (1) to the equivalent system in Byrnes-Isidori normal form [10]:

$$\left. \begin{aligned} y^{(r)} &= f(Y^{r-1}, z) + g(Y^{r-1}, z)u, \\ Y^{r-1}(0)^\top &= y^0 \in \mathbb{R}^r \\ \dot{z} &= h(Y^{r-1}, z), \quad z(0) = z^0 \in Z_0 \subseteq \mathbb{R}^{n-r} \end{aligned} \right\} \quad (5)$$

where f, g, h are locally Lipschitz continuous, g is positive and Z_0 is a possibly known restriction for the initial values of the z -system ($Z_0 = \mathbb{R}^{n-r}$ means that there is no knowledge). Furthermore, we assume that the z -system does not have a finite escape time for any bounded “input” vector Y^{r-1} , i.e.

$$\left. \begin{aligned} \forall Y^{r-1} \in \mathcal{L}^\infty(\mathbb{R}_{\geq 0} \rightarrow \mathbb{R})^r \quad \forall z_0 \in Z_0 \subseteq \mathbb{R}^{n-r} \\ \exists \text{ global solution } z : \mathbb{R}_{\geq 0} \rightarrow \mathbb{R}^{n-r} \text{ for} \\ \dot{z}(t) = h(Y^{r-1}(t), z(t)), \quad z(0) = z_0. \end{aligned} \right\} \quad (6)$$

Since we will consider non-continuous inputs u we have to allow for solutions in the sense of Carathéodory, i.e. $y^{(r-1)}$ and z are absolutely continuous and (5) holds almost everywhere. The original system (1) inherits this solution concept. For the implementation of the bang-bang funnel controller the knowledge of the Byrnes-Isidori normal form (and the corresponding coordinate transformation) is not needed, however in order to check the feasibility assumptions the knowledge of (at least certain bounds on) f, g and h is needed.

We call the z -system in (5) *bounded input bounded state (BIBS)* with respect to the “inputs” Y^{r-1} if

$$\left. \begin{aligned} \exists \gamma : \mathbb{R}^r \times \mathbb{R} \rightarrow \mathbb{R}_{\geq 0} \text{ continuous s. t. } \forall z_0 \in Z_0 \\ \forall Y^{r-1} = (y_0, \dots, y_{r-1}) \in \mathcal{L}^\infty(\mathbb{R}_{\geq 0} \rightarrow \mathbb{R})^r : \\ (6) \text{ holds and } \|z\|_\infty \leq \gamma(\|y_0\|_\infty, \dots, \|y_{r-1}\|_\infty, |z_0|). \end{aligned} \right\} \quad (7)$$

Finally, we assume that the controller is able to obtain the derivatives $\dot{e}, \ddot{e}, \dots, e^{(r-1)}$ of the error signal $e := y - y_{\text{ref}}$, in particular we have to make the following assumption on the reference signal:

(\mathbf{F}_2) $y_{\text{ref}} \in \mathcal{C}^{r-1}(\mathbb{R}_{\geq 0} \rightarrow \mathbb{R})$ and $y_{\text{ref}}^{(r-1)}$ is absolutely continuous with right-continuous derivative.

III. THE SWITCHING LOGIC

A. Overview and the structure of the switching logic

As indicated in Figure 1a the bang-bang control law is simply given by

$$u(t) = \begin{cases} U^-, & \text{if } q(t) = \text{true}, \\ U^+, & \text{if } q(t) = \text{false}, \end{cases} \quad (8)$$

where $q : \mathbb{R}_{\geq 0} \rightarrow \{\text{true}, \text{false}\}$ is the output of the switching logic \mathcal{S} which maps the error signal to the switching signal q .

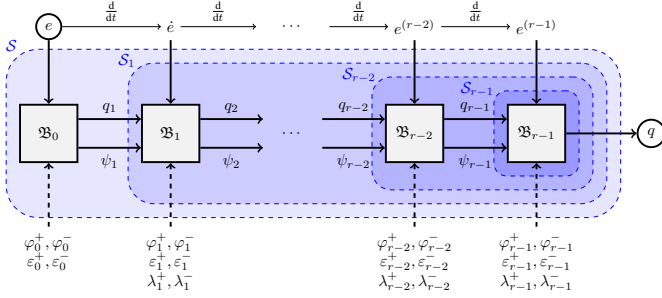

Fig. 2: Illustration of the structure of the switching logic (9). The meaning of the meta blocks $\mathcal{S}_1, \dots, \mathcal{S}_{r-1}$ will be discussed in Section VI, in particular, \mathcal{S}_i is given by (16).

The switching logic $\mathcal{S} : e \mapsto q$ is defined with the help of r blocks $\mathfrak{B}_0, \mathfrak{B}_1, \dots, \mathfrak{B}_{r-1}$ as follows, see also Figure 2:

$$\left. \begin{aligned} \mathcal{S}(e) &= \mathfrak{B}_{r-1}(e^{(r-1)}, q_{r-1}, \psi_{r-1}), \\ (q_i, \psi_i) &= \mathfrak{B}_{i-1}(e^{(i-1)}, q_{i-1}, \psi_{i-1}), \quad i = r-1, \dots, 2, \\ (q_1, \psi_1) &= \mathfrak{B}_0(e). \end{aligned} \right\} \quad (9)$$

Before formally defining the blocks \mathfrak{B}_i we want to highlight some important properties of the switching logic. Each block \mathfrak{B}_i tries to ensure that the i -th derivative of the error $e^{(i)}$ remains within the funnel

$$\mathcal{F}_i := \{ (t, e) \in \mathbb{R}_{\geq 0} \times \mathbb{R} \mid \varphi_i^-(t) \leq e \leq \varphi_i^+(t) \},$$

where $\varphi_i^\pm : \mathbb{R}_{\geq 0} \rightarrow \mathbb{R}$ are the desired funnel boundaries satisfying the forthcoming feasibility assumptions (\mathbf{F}_3) – (\mathbf{F}_8) ; in addition \mathfrak{B}_i ensures that $e^{(i)}$ is driven to a certain region specified by the input signals $q_i : [0, \infty) \rightarrow \{\text{true}, \text{false}\}$ and $\psi_i : [0, \infty) \rightarrow \mathbb{R}$. The meaning of the internal signals q_i and ψ_i , $i = 1, 2, \dots, r-1$ is as follows (see also Figure 6):

$$\begin{aligned} q_i = \text{true} &\Rightarrow \text{make } e^{(i)} \text{ smaller than } \min\{\psi_i, -\lambda_i^-\}, \\ q_i = \text{false} &\Rightarrow \text{make } e^{(i)} \text{ bigger than } \max\{\psi_i, \lambda_i^+\}. \end{aligned}$$

Here $\lambda_i^+, \lambda_i^- \in \mathbb{R}_{\geq 0}$ are design parameters of the block \mathfrak{B}_i representing a desired minimal or maximal value for $e^{(i)}$ (with the aim to increase or decrease the previous derivative $e^{(i-1)}$ by a certain rate). Finally, each block \mathfrak{B}_i also has the design parameters $\varepsilon_i^+, \varepsilon_i^- \in \mathbb{R}_{\geq 0}$, the *safety distances*, which trigger an event (hence a switch in the internal or external signals), when the error gets close to the funnel boundaries. The interpretation of the output q of the switching logic is similar as above: If $q = \text{true}$ we want to make $e^{(r)}$ negative enough so that $e^{(r-1)}$ decreases sufficiently fast and if $q = \text{false}$

we want to make $e^{(r)}$ positive enough to ensure a sufficiently increasing $e^{(r-1)}$. Due to the normal form (5) this can directly be achieved by choosing $u = U^-$ or $u = U^+$ accordingly with sufficiently large U^- and U^+ .

B. The definition of the blocks \mathfrak{B}_i

The main “ingredient” of each block \mathfrak{B}_i is the following elementary predicate function (to improve readability we highlight the second and third argument with different colors):

$$\mathfrak{S}(e, \bar{e}, \underline{e}, q_{\text{old}}) := [e \geq \bar{e} \vee (e > \underline{e} \wedge q_{\text{old}})], \quad (10)$$

for $e, \bar{e}, \underline{e} \in \mathbb{R}$ and $q_{\text{old}} \in \{\text{true}, \text{false}\}$. The corresponding dynamic logic system (DLS) on some interval $[t_0, t_1] \subseteq \mathbb{R}$ is given by

$$\begin{aligned} q(t) &= \mathfrak{S}(e(t), \bar{e}(t), \underline{e}(t), q(t-)), \\ q(t_0-) &= q^0 \in \{\text{true}, \text{false}\}, \end{aligned} \quad (11)$$

where $\bar{e}(\cdot)$ is the *upper switch trigger* and $\underline{e}(\cdot)$ is the *lower switch trigger* and $e(\cdot)$ is the “input” which drives the system. A typical behavior of the DLS (11) is shown in Figure 3.

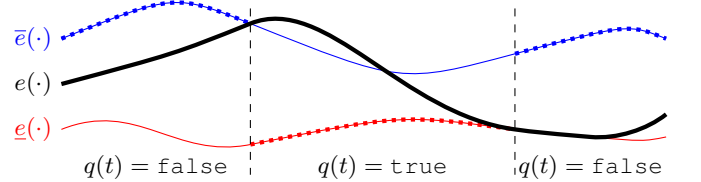

Fig. 3: Illustration of the basic switching predicate \mathfrak{S} and the corresponding DLS (11) for some given “input signal” $e(\cdot)$ (thick solid line). The dots indicate which switch trigger is active. Note that it is not assumed that $e(\cdot)$ is always contained within the lower switching trigger $\underline{e}(\cdot)$ and the upper switch trigger $\bar{e}(\cdot)$ and it is possible that $e(\cdot)$ is identical with one of the switching triggers for some time.

Invoking the simple switching predicate \mathfrak{S} the formal definitions of the DLSs represented by the blocks $\mathfrak{B}_0, \mathfrak{B}_1, \dots, \mathfrak{B}_{r-1}$ are as follows.

$$\begin{aligned} \mathfrak{B}_0 : e &\mapsto (q_1, \psi_1) \quad \text{with} \\ q_1(t) &= \mathfrak{S}(e(t), \varphi_0^+(t) - \varepsilon_0^+, \varphi_0^-(t) + \varepsilon_0^-, q_1(t-)), \\ q_1(0-) &= q_1^0 \in \{\text{true}, \text{false}\}, \\ \psi_1(t) &= \begin{cases} \dot{\varphi}_0^+(t), & \text{if } q_1(t) = \text{true}, \\ \dot{\varphi}_0^-(t), & \text{if } q_1(t) = \text{false}, \end{cases} \end{aligned}$$

$$\mathfrak{B}_i : (e^{(i)}, q_i, \psi_i) \mapsto (q_{i+1}, \psi_{i+1}), i = 1, \dots, r-2, \text{ with}$$

$$q_{i+1}(t) = \begin{cases} \mathfrak{S}(e^{(i)}(t), \psi_i^+(t) - \varepsilon_i^+, \varphi_i^-(t) + \varepsilon_i^-, q_{i+1}(t-)), \\ \quad \text{if } q_i(t) = \text{true}, \\ \mathfrak{S}(e^{(i)}(t), \varphi_i^+(t) - \varepsilon_i^+, \psi_i^-(t) + \varepsilon_i^-, q_{i+1}(t-)), \\ \quad \text{if } q_i(t) = \text{false}, \end{cases}$$

$$\psi_i^+(t) := \min\{\psi_i(t), -\lambda_i^-\}, \quad \psi_i^-(t) := \max\{\psi_i(t), \lambda_i^+\},$$

$$q_{i+1}(0-) = q_{i+1}^0 \in \{\text{true}, \text{false}\},$$

$$\psi_{i+1}(t) = \begin{cases} \dot{\psi}_i(t+), & \text{if } q_i(t) = \text{true} \wedge q_{i+1}(t) = \text{true}, \\ \dot{\varphi}_i^-(t), & \text{if } q_i(t) = \text{true} \wedge q_{i+1}(t) = \text{false}, \\ \dot{\varphi}_i^+(t), & \text{if } q_i(t) = \text{false} \wedge q_{i+1}(t) = \text{true}, \\ \dot{\psi}_i(t+), & \text{if } q_i(t) = \text{false} \wedge q_{i+1}(t) = \text{false}, \end{cases}$$

$$\mathfrak{B}_{r-1} : (e^{(r-1)}, q_{r-1}, \psi_{r-1}) \mapsto q \text{ given as above with}$$

$$i = r-1 \text{ and } q = q_r,$$

$$q(0-) = q^0 \in \{\text{true}, \text{false}\}.$$

Note that ψ_i will not be continuous in general, therefore $\dot{\psi}_i$ is not well defined. However, it will turn out that the switching logic ensures that ψ_i is piecewise continuously differentiable and $\dot{\psi}(t+)$ is then well defined.

Explicit definitions of the switching logic for the cases $r = 1$, $r = 2$ and $r = 3$ are given in the Appendix. For the case $r = 3$ a generic closed-loop behavior of the switching logic is illustrated in Figure 4 where, for simplicity, we have considered only constant funnel boundaries. The meaning of the internal variables q_1 and q_2 mentioned above is clearly visible: $q_1 \equiv \text{true}$ means we want to decrease the error e , i.e. we want to drive the derivative \dot{e} into the desired region $[-\lambda_1^-, \varphi_1^-]$. When we hit the lower safety distance for e we switch q_1 to $q_1 \equiv \text{false}$, which means now we want to increase e . Due to the higher relative degree we can not directly influence the error via the control input, hence we see a certain amount of overshoot.

C. A simple consequence of our forthcoming main results

If all funnel boundaries and the input values U^\pm are already fixed (e.g. due to physical constraints) then the feasibility assumptions in the next section can be checked and our forthcoming main result Theorem 4.1 shows then that feasibility is sufficient for the applicability of the bang-bang funnel controller. If one however has the freedom to choose the funnel boundaries for the derivatives of the error and also the input values U^\pm then combining our main result with the forthcoming Theorem 4.2 (stating that feasibility can be achieved by appropriately choosing the funnel boundaries) yields that the bang-bang funnel controller always works as long as the input values U^\pm are large enough:

Corollary 3.1 (Bang-bang funnel controller works): Consider the nonlinear system (1) satisfying (\mathbf{F}_1) with relative degree $r \geq 1$, bounded set Z_0 and the z -system being BIBS, a reference signal y_{ref} satisfying (\mathbf{F}_2) and, additionally, being

bounded with bounded derivatives, and a funnel \mathcal{F}_0 for the error signal $e := y - y_{\text{ref}}$ given by φ_0^\pm satisfying

- (\mathbf{F}_3^0) $\varphi_0^-(0) < e(0) < \varphi_0^+(0)$,
- (\mathbf{F}_4^0) $\varphi_0^+, \varphi_0^- \in \mathcal{W}^{r, \infty}(\mathbb{R}_{\geq 0} \rightarrow \mathbb{R})$, in particular $(\varphi_0^\pm)^{(i)}$, $i = 0, 1, \dots, r$ are (essentially) bounded,
- (\mathbf{F}_5^0) $\limsup_{t \rightarrow \infty} (\varphi_0^+(t) - \varphi_0^-(t)) > 0$.

Then there exist funnel boundaries φ_i^\pm , $i = 1, 2, \dots, r-1$, safety distances ε_i^\pm , $i = 0, 1, \dots, r-1$, and increase/decrease rates λ_i^\pm , $i = 1, 2, \dots, r-1$ such that the bang-bang funnel controller as given by (8), (9) and Section III-B works for large enough input values $U^+ > 0$ and $U^- < 0$, i.e.

- (i) the closed loop as shown Figure 1a has a global solution $(x, q) : \mathbb{R}_{\geq 0} \rightarrow \mathbb{R}^n \times \{\text{true}, \text{false}\}$,
- (ii) the error and its derivatives evolve within the funnels, i.e. $\varphi_i^-(t) \leq e^{(i)}(t) \leq \varphi_i^+(t)$ for all $t \geq 0$ and $i = 0, 1, \dots, r-1$,
- (iii) no Zeno behavior occurs, i.e. the switching signal q only switches finitely often on every finite time interval.

Remark 3.2 (Positivity of g in (5)): Assuming the existence of a global relative degree for system (1) already implies that g in (5) cannot attain the value zero, hence it must be sign-definite; it is therefore either globally positive or globally negative. All the results here hold of course true also when g is negative (just interchange the roles of U^+ and U^-), but the sign must be known a priori in order that the presented bang-bang funnel controller works. However, if the sign of g is not known one could add a second larger safety distance (as trigger for the switching logic) and the roles of U^+ and U^- are interchanged whenever the error hits the smaller safety distance. This second safety distance must be designed such that if the sign of g is guessed right at the beginning, the smaller safety distance will never be hit and, if the sign is guessed wrongly, then the smaller safety distance is such that the error remains within the funnel when the right U^+ and U^- values are used. The corresponding adjustments of the feasibility assumptions are straightforward and therefore omitted.

IV. FEASIBILITY ASSUMPTIONS AND MAIN RESULT

A. Conditions on the funnel boundaries

We have to assume that the funnel boundaries initially are large enough to contain the initial error with a ‘‘safe’’ distance, i.e.

- (\mathbf{F}_3) $e^{(i)}(0) \in [\varphi_i^-(0) + \varepsilon_i^-, \varphi_i^+(0) - \varepsilon_i^+]$, $i = 0, \dots, r-1$.

The funnel boundaries have to be at least as smooth as the corresponding error signal evolving within it, hence we make the following smoothness and boundedness assumptions on the funnel boundaries.

- (\mathbf{F}_4) $\varphi_i^+, \varphi_i^- \in \mathcal{W}^{r-i, \infty}(\mathbb{R}_{\geq 0} \rightarrow \mathbb{R})$, $i = 0, 1, \dots, r-1$, in particular, φ_i^\pm and its derivatives are bounded.

Since the control objective is to keep the error signal within the corresponding funnel, the error must be able to decrease or increase at least as fast as the funnel boundary, hence we have to choose the funnel \mathcal{F}_1 large enough such that it contains the derivatives $\dot{\varphi}_0^\pm$ of the funnel boundaries φ_0^\pm of \mathcal{F}_0 . An analogous condition must also hold for the funnels \mathcal{F}_i and

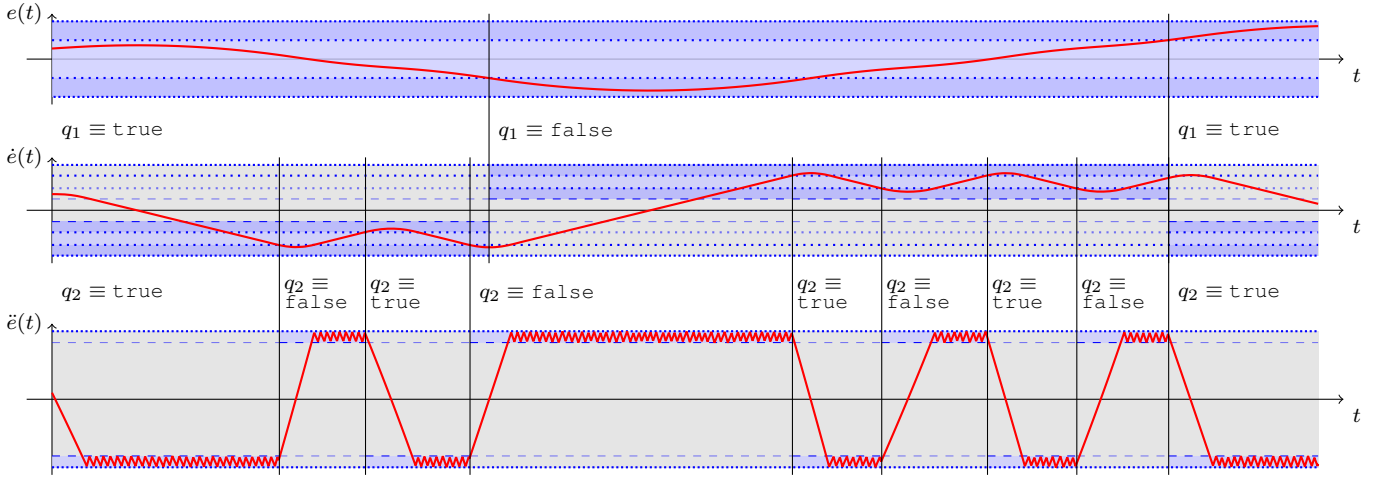

Fig. 4: Schematic illustration of the closed-loop behavior of the bang-bang funnel controller for relative degree three case and constant funnel boundaries \cdots ; the desired increase rate $\lambda_1^+ = \lambda_1^- > 0$ and $\lambda_2^+ = \lambda_2^- > 0$ are drawn with $- -$, the desired regions for $e^{(i)}$ in \mathcal{F}_i are highlighted as well as the safety region (given by $\varepsilon_0^+ = \varepsilon_0^- > 0$ and $\varepsilon_1^+ = \varepsilon_1^- > 0$ drawn with \cdots ; $\varepsilon_2^\pm > 0$ is so small that it is not shown).

the derivatives of their boundaries. Furthermore, the desired increase/decrease rate λ_i^\pm for the error signal $e^{(i-1)}$ must be consistent with the funnel \mathcal{F}_i . Additionally, the safety regions are not allowed to overlap. Altogether, we obtain the following feasibility assumption.

$$\begin{aligned}
 (\mathbf{F}_5) \quad & \forall t \geq 0 : \varphi_0^+(t) - \varepsilon_0^+ > \varphi_0^-(t) + \varepsilon_0^- \text{ and } \forall i \in \{1, \dots, r-1\}: \\
 & \varphi_i^+(t) - \varepsilon_i^+ > \varepsilon_i^- + \\
 & \max\{(\varphi_0^-)^{(i)}(t), (\varphi_1^-)^{(i-1)}(t), \dots, \dot{\varphi}_{i-1}^-(t), \lambda_i^+\}, \\
 & \varphi_i^-(t) + \varepsilon_i^- < -\varepsilon_i^+ + \\
 & \min\{(\varphi_0^+)^{(i)}(t), (\varphi_1^+)^{(i-1)}(t), \dots, \dot{\varphi}_{i-1}^+(t), -\lambda_i^-\}.
 \end{aligned}$$

B. The settling times

For each block \mathfrak{B}_i we would like to ensure that the signal $e^{(i)}$ is in the desired region (specified by ψ_i and q_i) after a specific time. Therefore, we have to assume the existence of numbers $\Delta_i^+ > 0$, $\Delta_i^- > 0$ for $i = 0, 1, \dots, r-1$ and $\Delta_r^+ \geq 0$, $\Delta_r^- \geq 0$ such that

$$\begin{aligned}
 (\mathbf{F}_6) \quad & \Delta_i^+ \geq \Delta_{i+1}^+ + \frac{\|\varphi_i^+\|_\infty + \|\varphi_i^-\|_\infty}{\lambda_{i+1}^+} \text{ and } \Delta_i^- \geq \Delta_{i+1}^- + \\
 & \frac{\|\varphi_i^+\|_\infty + \|\varphi_i^-\|_\infty}{\lambda_{i+1}^-}, \quad i = 0, \dots, r-1,
 \end{aligned}$$

as well as

$$\begin{aligned}
 (\mathbf{F}_7) \quad & \varepsilon_i^+ > \Delta_{i+2}^+ \|\dot{\psi} - \varphi_{i+1}^+\|_\infty + \frac{(\|\dot{\psi}\|_\infty + \|\varphi_{i+1}^+\|_\infty)^2}{2\lambda_{i+2}^+}, \quad \psi \in \\
 & \{\varphi_i^+, \dot{\varphi}_{i-1}^+, \dots, (\varphi_0^+)^{(i)}\}, \text{ for } i = 0, 1, \dots, r-2 \text{ and} \\
 & \varepsilon_i^- > \Delta_{i+2}^- \|\dot{\psi} - \varphi_{i+1}^-\|_\infty + \frac{(\|\dot{\psi}\|_\infty + \|\varphi_{i+1}^-\|_\infty)^2}{2\lambda_{i+2}^-}, \quad \psi \in \\
 & \{\varphi_i^-, \dot{\varphi}_{i-1}^-, \dots, (\varphi_0^-)^{(i)}\}, \text{ for } i = 0, 1, \dots, r-2.
 \end{aligned}$$

It will turn out that the feasibility assumption (\mathbf{F}_6) yields (provided the other feasibility assumptions are satisfied) that the numbers Δ_i^\pm are upper bounds of the *settling times* in the sense that within a time-span of Δ_i^\pm the switching logic of block \mathfrak{B}_i ensures that $e^{(i)}$ has reached the desired region given by ψ_i and q_i . The intuition of (\mathbf{F}_6) is then as follows:

Assume we already know that the block \mathfrak{B}_{i+1} ensures that $e^{(i+1)}(t)$ is at least $-\lambda_{i+1}^-$ (if q_i is true) or at most λ_{i+1}^+ (if q_i is false) after the corresponding settling time Δ_{i+1}^- or Δ_{i+1}^+ .

Then it takes an additional time of at most $\frac{\|\varphi_i^+\|_\infty + \|\varphi_i^-\|_\infty}{\lambda_{i+1}^-}$

or $\frac{\|\varphi_i^+\|_\infty + \|\varphi_i^-\|_\infty}{\lambda_{i+1}^+}$ for the error signal $e^{(i)}$ to move from the upper funnel boundary φ_i^+ to the lower funnel boundary φ_i^- or vice versa and definitely reaching the desired region on its way.

In general, larger values for the settling times yield larger overshoots. Hence the safety distances must be large enough to prevent the signals $e^{(i)}$ leaving its corresponding funnel, resulting in the above feasibility assumption (\mathbf{F}_7) .

Note that for $i = r-1$ the additional parameters $\lambda_r^+ > 0$ and $\lambda_r^- > 0$ appear in (\mathbf{F}_6) and (\mathbf{F}_7) . These parameters reflect the maximal rate for the increase and decrease of the error signal $e^{(r-1)}$, which can be directly influenced by the input (due to the relative degree assumption, see the next section). Furthermore, note that we can allow $\lambda_1^\pm = 0$ and $\Delta_0^\pm = \Delta_1^\pm = \infty$, because the settling times of the blocks \mathfrak{B}_0 and \mathfrak{B}_1 don't play any role in (\mathbf{F}_7) and in the forthcoming analysis.

C. Feasibility of U^+ and U^-

Up to now the feasibility assumptions did not depend on the system (apart from the structural assumptions in Section II-B) or on the actual input values U^+ and U^- . The final feasibility assumption basically says that U^+ should be large enough and that U^- should be small enough in order to achieve the control objectives. What "large or small enough" means depends, firstly, on the necessary increase/decrease rates λ_r^\pm coming from the previous feasibility assumption (in particular on the shapes of the funnels) together with the following feasibility assumption, which ensures that the increase/decrease rate for $e^{(r-1)}$ suffices to keep $e^{(r-1)}$ within the last funnel \mathcal{F}_{r-1} and the specified regions.

$$(F_8) \quad \lambda_r^+ > \max\{\dot{\varphi}_{r-1}^-(t), \ddot{\varphi}_{r-2}^-(t), \dots, (\varphi_0^-)^{(r)}(t)\} \text{ and} \\ -\lambda_r^- < \min\{\dot{\varphi}_{r-1}^+(t), \ddot{\varphi}_{r-2}^+(t), \dots, (\varphi_0^+)^{(r)}(t)\} \text{ for} \\ \text{all } t \geq 0.$$

The necessary size for the input depends, secondly, on how fast y_{ref} changes and, thirdly, of course on the system itself. For example, the closer the positive function g in (5) gets to zero the bigger the amplitude of the input must be. Altogether this yields the final feasibility assumption.

$$(F_9) \quad U^+ \geq \frac{\lambda_r^+ + y_{\text{ref}}^{(r)}(t) - f(y_t^0, y_t^1, \dots, y_t^{r-1}, z_t)}{g(y_t^0, y_t^1, \dots, y_t^{r-1}, z_t)} \text{ and} \\ U^- \leq \frac{-\lambda_r^- + y_{\text{ref}}^{(r)}(t) - f(y_t^0, y_t^1, \dots, y_t^{r-1}, z_t)}{g(y_t^0, y_t^1, \dots, y_t^{r-1}, z_t)} \text{ for} \\ \text{all } t \geq 0, (y_t^0, y_t^1, \dots, y_t^{r-1}) \in \Phi_t^{y_{\text{ref}}}, z_t \in Z_t^{y_{\text{ref}}}, \\ \text{where } \mathbb{R}^r \supseteq \Phi_t^{y_{\text{ref}}} :=$$

$$\left\{ (y_0, \dots, y_{r-1}) \left| \begin{array}{l} \forall i \in \{0, 1, \dots, r-1\} : \\ y_i - y_{\text{ref}}^{(i)}(t) \in [\varphi_i^-(t), \varphi_i^+(t)] \end{array} \right. \right\} (12)$$

and $Z_t^{y_{\text{ref}}} :=$

$$\left\{ z(t) \left| \begin{array}{l} z \text{ solves } \dot{z} = h(y, \dot{y}, \dots, y^{(r-1)}, z), \\ z(0) = z_0, \text{ for some } z_0 \in Z_0 \text{ and} \\ \text{some } y \in C^{r-1} \text{ with } (y(\tau), \dots, \\ y^{(r-1)}(\tau)) \in \Phi_\tau^{y_{\text{ref}}}, \tau \in [0, t] \end{array} \right. \right\}, (13)$$

where $Z_0 \subseteq \mathbb{R}^{n-r}$ is the set of possible initial values for the z -system in (5).

Note that the structural assumption (6) ensures that $Z_t^{y_{\text{ref}}}$ is well defined and bounded when Z_0 is bounded, however the latter is not assumed here and neither is it assumed that $Z_t^{y_{\text{ref}}}$ is uniformly bounded in t .

D. The main result

We are now in the position to formulate our main result of this work, which states that the above feasibility assumptions are sufficient for the applicability of the proposed bang-bang funnel controller.

Theorem 4.1 (The bang-bang funnel controller works): Consider the non-linear system (1) satisfying (F_1) with known relative degree $r > 0$, a reference signal y_{ref} satisfying (F_2) , the funnels \mathcal{F}_i given as in (3) via the funnel boundaries φ_i^+ and φ_i^- , $i = 0, 1, \dots, r-1$ satisfying $(F_4) - (F_7)$ and the bang-bang funnel controller given by the switching logic defined in Section III driven by the error $e = y - y_{\text{ref}}$. If the initial values² $e(0), \dot{e}(0), \dots, e^{(r-1)}(0)$ are ‘‘safely’’ contained within the corresponding funnels, i.e. (F_3) holds, and the input values U^+, U^- are large enough in the sense of (F_8) and (F_9) then the closed loop as in Figure 2 has a global solution $(x, q) : [0, \infty) \rightarrow \mathbb{R}^n \times \{\text{true}, \text{false}\}$ such that q has only locally finitely many switches and the error and its derivatives evolve within the funnels, i.e. $e^{(i)}(t) \in [\varphi_i^-(t), \varphi_i^+(t)]$ for all $t \geq 0$ and all $i \in \{0, 1, \dots, r-1\}$.

The proof is carried out in Section VI which itself is based on the well posedness result in Section V.

²due to the structural assumption (F_1) the initial values $e(0), \dot{e}(0), \dots, e^{(r-1)}(0)$ are given by x^0 and do not depend on $u(0)$.

E. Satisfiability of the feasibility assumptions

On a first glance the feasibility assumptions look rather technical and it is also not immediately clear whether they are satisfiable at all. The next result resolves this issue.

Theorem 4.2 (Feasibility): Consider a funnel \mathcal{F}_0 given by φ_0^+ and φ_0^- satisfying (F_3^0) , (F_4^0) , (F_5^0) (see Corollary 3.1). Then there exist funnels \mathcal{F}_i given by φ_i^\pm , $i = 1, \dots, r-1$, and parameters $\varepsilon_i^\pm \in \mathbb{R}_{\geq 0}$, $i = 0, \dots, r-1$, $\lambda_i^\pm \in \mathbb{R}$, $i = 1, \dots, r$ such that the feasibility assumptions $(F_3) - (F_8)$ hold. If, in addition, the internal dynamics given by the z -system in (5) are BIBS with respect to the inputs $y, \dot{y}, \dots, y^{(r-1)}$, the set of initial values Z_0 is bounded and $y_{\text{ref}}^{(j)}$ is bounded for $j = 0, 1, \dots, r$ then (F_9) is satisfied for large enough U^+ and $-U^-$.

Proof: For the proof of the first claim we split (F_6) and (F_7) each into two sufficient conditions:

$$(F_6^a) \quad \Delta_{i+1}^+ < \Delta_i^+ \text{ and } \Delta_{i+1}^- < \Delta_i^- \text{ for } i = 0, \dots, r-1. \\ (F_6^b) \quad \lambda_{i+1}^+ \geq \frac{\|\varphi_i^+\|_\infty + \|\varphi_{i+1}^-\|_\infty}{\Delta_i^+ - \Delta_{i+1}^+} \text{ and } \lambda_{i+1}^- \geq \frac{\|\varphi_i^-\|_\infty + \|\varphi_{i+1}^+\|_\infty}{\Delta_i^- - \Delta_{i+1}^-} \\ \text{for } i = 0, \dots, r-1. \\ (F_7^a) \quad \Delta_{i+1}^+ < \frac{\varepsilon_{i-1}^+}{2\|\psi - \varphi_i^+\|_\infty}, \psi \in \{\varphi_{i-1}^+, \dot{\varphi}_{i-2}^+, \dots, (\varphi_0^+)^{(i-1)}\}, \\ i = 1, 2, \dots, r-1, \text{ and } \Delta_{i+1}^- < \frac{\varepsilon_{i-1}^-}{2\|\psi - \varphi_i^-\|_\infty}, \psi \in \\ \{\varphi_{i-1}^-, \dot{\varphi}_{i-2}^-, \dots, (\varphi_0^-)^{(i-1)}\}, i = 1, 2, \dots, r-1, \\ (F_7^b) \quad \lambda_{i+1}^+ \geq \frac{(\|\psi\|_\infty + \|\varphi_i^-\|_\infty)^2}{\varepsilon_{i-1}^+}, \psi \in \{\varphi_{i-1}^-, \dot{\varphi}_{i-2}^-, \dots, (\varphi_0^-)^{(i-1)}\}, \\ i = 1, \dots, r-1, \text{ and } \lambda_{i+1}^- \geq \frac{(\|\psi\|_\infty + \|\varphi_i^+\|_\infty)^2}{\varepsilon_{i-1}^-}, \psi \in \\ \{\varphi_{i-1}^+, \dot{\varphi}_{i-2}^+, \dots, (\varphi_0^+)^{(i-1)}\}, i = 1, 2, \dots, r-1.$$

Assumptions (F_3^0) and (F_5^0) ensure existence of $\varepsilon_0^+, \varepsilon_0^- \in \mathbb{R}_{>0}$ such that Assumptions (F_3) and (F_5) hold for $i = 0$. Furthermore, choose $\Delta_0^+ > 0, \Delta_0^- > 0$ arbitrary and let, for notational convenience, $\lambda_0^+ = \lambda_0^- = 0$.

Inductively, assume now that, for some $i \in \{0, 1, \dots, r-2\}$ we have already chosen $\varphi_j^\pm, \varepsilon_j^\pm, \Delta_j^\pm$ and λ_j^\pm for $j = 0, 1, \dots, i$ such that (F_3) , (F_4) and (F_5) hold up to the index i , (F_6) holds up to index $i-1$ and (F_7) holds up to index $i-2$.

We can now choose $\Delta_{i+1}^+ > 0$ and $\Delta_{i+1}^- > 0$ small enough such that (F_6^a) and (F_7^a) hold for the index i . Afterwards we can choose λ_{i+1}^\pm large enough such that (F_6^b) and (F_7^b) hold for the index i . Choose any $\varepsilon_{i+1}^+ > 0$ and $\varepsilon_{i+1}^- > 0$, then we can choose a wide enough funnel \mathcal{F}_{i+1} given by sufficiently smooth (according to (F_4)) boundaries φ_{i+1}^+ and φ_{i+1}^- such that (F_3) and (F_5) for the index $i+1$ are satisfied. Altogether we were able to find $\varphi_j^\pm, \varepsilon_j^\pm, \Delta_j^\pm$ and λ_j^\pm for $j = 0, 1, \dots, i+1$ such that (F_3) , (F_4) and (F_5) hold up to the index $i+1$, (F_6) holds up to index i and (F_7) holds up to index $i-1$.

Finally we can choose $\Delta_r = 0$ and λ_r sufficiently large such that (F_6^b) , (F_7^b) and (F_8) holds.

In order to show that (F_9) is satisfied for large enough U^+ and $-U^-$, we first observe that the boundedness assumption on y_{ref} together with boundedness of the funnel boundaries ensures that $\Phi_t^{y_{\text{ref}}}$ is uniformly bounded in t . Now the BIBS-assumption together with boundedness of Z_0 implies boundedness of Z_t uniformly in t . Altogether, there exists compact sets $Y \subseteq \mathbb{R}^r$ and $Z \subseteq \mathbb{R}^{n-r}$ such that $\Phi_t^{y_{\text{ref}}} \subseteq Y$ and $Z_t \subseteq Z$ for all $t \geq 0$. Continuity of f and g imply that f is bounded in magnitude on the compact set $Y \times Z$, say by $\bar{f} > 0$, and g

is bounded away from zero on $Y \times Z$, say by $\underline{g} > 0$. Hence any U^- and U^+ with

$$U^+ > \frac{\lambda_r + \|y_{\text{ref}}^{(r)}\|_\infty + \bar{f}}{\underline{g}} \quad \text{and} \quad U^- < \frac{-\lambda_r - \|y_{\text{ref}}^{(r)}\|_\infty - \bar{f}}{\underline{g}}$$

will make (\mathbf{F}_g) true. \blacksquare

Remark 4.3 (Competing control objectives): Although Theorem 4.2 shows that the error funnel \mathcal{F}_0 can nearly be arbitrary, it should be clear that more strict control objectives will lead to very large values for the input and also fast switching. Furthermore, following the proof of Theorem 4.2 might yield very conservative values for U^\pm . An overestimation of the sufficient input values can be avoided by allowing time-varying safety distances $\varepsilon_0^+, \varepsilon_0^-$. The problem of a constant safety distance is most apparent when a fast transient behavior is desired which is expressed with large values of $\dot{\varphi}_0^\pm(t)$ together with high demands on the tracking accuracy, expressed by a small value of $\varphi_0^+(t) - \varphi_0^-(t)$ for $t \gg 0$. The latter enforces the safety distance ε_0^\pm to be small as well. However, a small safety distance will give the error not much time to “turn the corner” which is a particular problem when the funnel boundary shrinks rapidly (i.e. fast transient behavior is desired). Often the funnel boundaries decrease monotonically and the highest rate of change of the funnel boundaries is at the beginning where also the size of the funnel boundary is large. Hence in this situation a much larger safety distance would be possible. In our theoretical results we haven’t formalized the possibility for a time-varying safety distance, because the proofs are already technical enough. However, an illustration of using a time-varying safety distance can be found in the case study [14].

V. WELL-POSEDNESS OF THE CLOSED LOOP

The closed loop as shown in Figure 1a is a *hybrid system*, i.e. it consists of continuous dynamics governed by (1) and discrete dynamics given by the switching logic (9). Hence it is not clear in general whether for any initial value $(x^0, \mathbf{q}^0) \in \mathbb{R}^n \times \{\text{true}, \text{false}\}^r$ with $\mathbf{q}^0 = (q_1^0, q_2^0, \dots, q_{r-1}^0, q^0)$ and any reference signal y_{ref} there exists at least a local solution $(e, q) : [0, \omega) \rightarrow \mathbb{R} \times \{\text{true}, \text{false}\}$ for some $\omega > 0$. The following lemma shows that *right-continuity* of the switching signal q in the open loop alone suffices to show existence of a local maximally extended solution of the closed loop.

Lemma 5.1 (Right-continuity & well-posedness, cf. [13]): Consider system (1) satisfying (\mathbf{F}_1) with the controller (8) governed by some switching signal q which is generated by some causal³ switching logic $\mathcal{L}_{y_{\text{ref}}} : y \mapsto q$. Let $\mathcal{Y} \subseteq \{y : [0, \omega) \rightarrow \mathbb{R} \mid 0 < \omega \leq \infty\}$ be a function space which contains all possible outputs of (1) for arbitrary locally integrable inputs u (we do not exclude finite escape time at this point). If for every $y \in \mathcal{Y}$ defined on $[0, \omega_y)$ the resulting switching signal q is *right-continuous* then the closed loop

³In general, causality does not allow $q(t)$ to depend on the derivatives $y^{(i)}(t)$, however because of the normal form (5) the values $\dot{y}(t), \dots, y^{(r-1)}(t)$ do not depend on $q(t)$. Hence in the present situation, causality does not exclude that $q(t)$ depends on $\dot{y}(t), \dots, y^{(r-1)}(t)$

consisting of (1), (8) and $\mathcal{L}_{y_{\text{ref}}}$ is well posed, i.e. for every initial value $x^0 \in \mathbb{R}^n$ there exists a maximally extended solution $(x, q) : [0, \omega) \rightarrow \mathbb{R}^n \times \{\text{true}, \text{false}\}$, $0 < \omega \leq \omega_y \leq \infty$.

Proof: The proof is straight-forward and identical to the one in [13, Lem. A.1] and therefore omitted. \blacksquare

Note that Lemma 5.1 does not exclude Zeno behavior, i.e. it is not excluded yet that the switching times accumulate and the solution stops at the accumulation point. However, it excludes the appearance of so-called Filippov solutions [2] or sliding modes, because for each initial value there is a (local) classical solution starting at this initial value.

The following lemma shows that the DLS (11) induced by the elementary switching predicate \mathfrak{S} given by (10) produces right-continuous outputs provided the switching triggers are continuous and do not intersect. This is an essential property which will be used together with Lemma 5.1 to show the well-posedness of the closed loop from Figure 1a.

Lemma 5.2 (Property of the DLS induced by \mathfrak{S}): Consider the DLS (11) on some interval $[t_0, t_1) \subseteq \mathbb{R}$ with some $q^0 \in \{\text{true}, \text{false}\}$. Assume $e, \bar{e}, \underline{e} : [t_0, t_1) \rightarrow \mathbb{R}$ are continuous and, additionally,

$$\forall t \in [t_0, t_1) : \bar{e}(t) > \underline{e}(t). \quad (14)$$

Then (11) has a unique solution $q : [t_0, t_1) \rightarrow \{\text{true}, \text{false}\}$ which is right-continuous, i.e. for all $t \in [t_0, t_1)$ there exists $\varepsilon > 0$ such that q is constant on $[t, t + \varepsilon)$. Furthermore, the jumps of q cannot accumulate within any compact subset of $[t_0, t_1)$, in particular, $q(t-) := \lim_{\varepsilon \searrow 0} q(t - \varepsilon)$ is for all $t \in (0, \omega)$ well defined.

Proof: By construction, for any fixed $t \in [t_0, t_1)$, $q_{\text{new}} := \mathfrak{S}(e(t), \bar{e}(t), \underline{e}(t), q_{\text{old}}) \neq q_{\text{old}}$ if, and only if, $q_{\text{old}} = \text{false}$ and the upper trigger is hit, i.e. $e(t) \geq \bar{e}(t)$, or $q_{\text{old}} = \text{true}$ and the lower trigger is hit, i.e. $e(t) \leq \underline{e}(t)$. By continuity of $e, \bar{e}, \underline{e}$ and by (14) it follows that $q_{\text{new}} \neq q_{\text{old}}$ implies that $\mathfrak{S}(e(t+\tau), \bar{e}(t+\tau), \underline{e}(t+\tau), q_{\text{new}}) = q_{\text{new}}$ for all small enough $\tau > 0$. In particular, there exists $\varepsilon > 0$ such that any $q : [t_0, t_1) \rightarrow \{\text{true}, \text{false}\}$ with either $q|_{[t_0, t_0+\varepsilon)} \equiv \text{true}$ or $q|_{[t_0, t_0+\varepsilon)} \equiv \text{false}$ solves the DLS (11) on $[t_0, t_0+\varepsilon)$. Choose the maximal $\varepsilon > 0$ such that the constant $q|_{[t_0, t_0+\varepsilon)}$ solves the DSL (11). This implies that at the time $t + \varepsilon$ a trigger was hit, i.e. $q(t + \varepsilon) \neq q((t + \varepsilon)-)$ and we now can continue the solution by a constant value again. Hence we have shown that we can extend the solution onto a maximal interval $[t_0, \omega)$. It remains to show that $\omega = t_1$. Seeking a contradiction, assume $\omega < t_1$ which implies $\omega < \infty$. Let $\delta := \bar{e}(\omega) - \underline{e}(\omega) > 0$. By continuity of $e, \bar{e}, \underline{e}$ there exists $\varepsilon > 0$ such that

$$\forall t \in (\omega - \varepsilon, \omega) : |e(t) - e(\omega)| < \delta/2, \\ |\bar{e}(t) - \bar{e}(\omega)| < \delta/4, \quad |\underline{e}(t) - \underline{e}(\omega)| < \delta/4.$$

This implies that either $e(t) > \underline{e}(t)$ for all $t \in (\omega - \varepsilon, \omega)$ or $e(t) < \bar{e}(t)$ on $(\omega - \varepsilon, \omega)$, hence there can be at most one jump of q on $(\omega - \varepsilon, \omega)$. Therefore $q(\omega-)$ is well defined and yields a unique $q(\omega)$ which can be, as above, extended. This contradicts maximality of ω . In particular, this shows that the jumps of q cannot accumulate in any compact subset of $[t_0, t_1)$, whence, $q(t-)$ is well defined for all $t \in [t_0, t_1)$. \blacksquare

In order to use Lemma 5.1, observe that the normal form (5) of system (1) implies that for any locally integrable input function u the output y is $r - 1$ times continuously differentiable, hence the output space \mathcal{Y} is contained in the set of all such $y : [0, \omega) \rightarrow \mathbb{R}$ with $\omega \in (0, \infty]$. We are now able to formulate sufficient conditions which ensure well-posedness of the closed loop.

Theorem 5.3 (Well-posedness of the closed loop): Consider the non-linear system (1) satisfying (\mathbf{F}_1) with known relative degree $r > 0$, a reference signal y_{ref} satisfying (\mathbf{F}_2) , the funnels \mathcal{F}_i given as in (3) via the funnel boundaries φ_i^+ and φ_i^- , $i = 0, 1, \dots, r - 1$ satisfying (\mathbf{F}_4) , (\mathbf{F}_5) and the bang-bang funnel controller given as in Section III driven by the error $e = y - y_{\text{ref}}$. Then the closed loop as in Figure 1a has for all initial values $x^0 \in \mathbb{R}^n$, $\mathbf{q}^0 \in \{\text{true}, \text{false}\}^r$ a unique maximally extended solution $(x, q) : [0, \omega) \rightarrow \mathbb{R}^n \times \{\text{true}, \text{false}\}^r$, $\omega \in (0, \infty]$. Furthermore, q has in each compact interval within $[0, \omega)$ only finitely many jumps.

Proof: Due to Lemma 5.1 it suffices to show that the switching logic \mathcal{S} induces a causal operator $\mathcal{L}_{y_{\text{ref}}} : y \mapsto q$ such that for all possible outputs y the resulting switching signal q is right-continuous. First note that the open-loop output y of (1) for any locally integrable input u fulfills $y \in \mathcal{Y} := \{y : [0, \omega) \rightarrow \mathbb{R} \mid \omega \in (0, \infty], y \in \mathcal{C}^{r-1}\}$. Hence, invoking (\mathbf{F}_2) , also $e \in \mathcal{Y}$, in particular, $e^{(i)}$ is continuous for $i = 0, 1, \dots, r - 1$.

We will carry out an inductive argument to show that for all $j \in \{1, \dots, r - 1\}$ the following *claim* holds: There exists a sequence $(t_k)_{k \in \mathbb{N}}$ with $t_0 = 0$ and $t_k \rightarrow \omega$ for $k \rightarrow \infty$ such that $q_j|_{[t_k, t_{k+1})}$ is constant, $\psi_j \in \mathcal{C}_{\text{pw}}^{r-j-1}$ with

$$\psi_j = \sum_{k \in \mathbb{N}} (\theta_k)_{[t_k, t_{k+1})}$$

and $\theta_k \in \mathcal{C}^{r-j-1}([0, \infty) \rightarrow \mathbb{R})$ fulfills either $\theta_k \in \{(\varphi_0^+)^{(j)}, (\varphi_1^+)^{(j-1)}, \dots, \dot{\varphi}_{j-1}^+\}$ if $q_j|_{[t_k, t_{k+1})} \equiv \text{true}$ or $\theta_k \in \{(\varphi_0^-)^{(j)}, (\varphi_1^-)^{(j-1)}, \dots, \dot{\varphi}_{j-1}^-\}$ otherwise.

To show this claim for $j = 1$, consider a fixed error signal $e \in \mathcal{C}^{r-1}([0, \omega) \rightarrow \mathbb{R})$. Lemma 5.2 together with (\mathbf{F}_4) and (\mathbf{F}_5) , applied to $i = 0$, yields that the DLS for q_1 in the \mathfrak{B}_0 -block has a unique solution $q_1 : [0, \omega) \rightarrow \{\text{true}, \text{false}\}$ for which there exists a strictly increasing sequence $(t_k)_{k \in \mathbb{N}}$ with $t_0 = 0$ and $t_k \rightarrow \omega$ as $k \rightarrow \infty$ such that $q_1|_{[t_k, t_{k+1})}$ is constant. Therefore $\psi_1 \in \mathcal{C}_{\text{pw}}^{r-2}$, in particular

$$\psi_1 = \sum_{k \in \mathbb{N}} (\theta_k)_{[t_k, t_{k+1})},$$

where $\theta_k \in \mathcal{C}^{r-2}([0, \infty) \rightarrow \mathbb{R})$ is either $\dot{\varphi}_0^+$ if $q_1 = \text{true}$ on the corresponding interval or $\dot{\varphi}_0^-$ otherwise.

Assume that the above claim holds for the index j . To show the claim for $j + 1$ consider the block \mathfrak{B}_j on the extended intervals $[t_k, t_{k+1} + \varepsilon)$ where $\varepsilon > 0$ and with input θ_k instead of ψ_j . Then Lemma 5.2 applied to each extended interval $[t_k, t_{k+1} + \varepsilon)$ together with (\mathbf{F}_5) (applied to index $i = j$) implies that the DLS of Block \mathfrak{B}_j yields a unique right-continuous solution q_{j+1}^k on $[t_k, t_{k+1} + \varepsilon)$ for all initial values $q_{j+1}^k(t_k^-)$. Furthermore, q_{j+1}^k has only finitely many jumps on the compact interval $[t_k, t_{k+1}]$ and

$q_{j+1}^k(t_{k+1}^-)$ is well defined. Choosing inductively as initial condition $q_{j+1}^{k+1}(t_{k+1}^-) = q_{j+1}^k(t_{k+1}^-)$ we see that

$$q_{j+1} := \sum_{k \in \mathbb{N}} (q_{j+1}^k)_{[t_k, t_{k+1})}$$

is the unique solution of the DLS in block \mathfrak{B}_j with inputs q_j and ψ_j . Since q_{j+1} has finitely many jumps in each compact interval, there exists a sequence $(s_k)_{k \in \mathbb{N}}$ with $s_k \rightarrow \omega$ as $k \rightarrow \infty$ such that $q_{j+1}|_{[s_k, s_{k+1})}$ is constant. Consequently, the second output $\psi_{j+1} \in \mathcal{C}_{\text{pw}}^{r-j}$ of the block \mathfrak{B}_i can be written as

$$\psi_{j+1} = \sum_{k \in \mathbb{N}} (\eta_k)_{[s_k, s_{k+1})}$$

where $\eta_k \in \mathcal{C}^{r-i}$ fulfills either

$$\begin{aligned} \eta_k &\in \{(\varphi_0^+)^{(j+1)}, (\varphi_1^+)^{(j)}, \dots, \dot{\varphi}_{j-1}^+, \dot{\varphi}_j^+\} \\ &\text{if } q_{j+1}|_{[s_k, s_{k+1})} \equiv \text{true} \quad \text{or} \\ \eta_k &\in \{(\varphi_0^-)^{(j+1)}, (\varphi_1^-)^{(j)}, \dots, \dot{\varphi}_{j-1}^-, \dot{\varphi}_j^-\} \\ &\text{if } q_{j+1}|_{[s_k, s_{k+1})} \equiv \text{false}. \end{aligned}$$

This proves the claim.

Applying the above arguments a last time to the block \mathfrak{B}_{r-1} results in a right-continuous unique solution $q : [0, \omega) \rightarrow \{\text{true}, \text{false}\}$ of the DLS in \mathfrak{B}_{r-1} which has in each compact interval within $[0, \omega)$ only finitely many jumps. ■

VI. PROOF OF THE MAIN RESULT

In order to prove Theorem 4.1 we rewrite the definition of the switching logic \mathcal{S} in a recursive way (see also Figure 2):

$$\mathcal{S} : e \mapsto q := \mathcal{S}_1(\dot{e}, \mathfrak{B}_0(e)) = \mathcal{S}_1(\dot{e}, q_1, \psi_1), \quad (15)$$

where, for $i = 1, \dots, r - 2$,

$$\begin{aligned} \mathcal{S}_i : (e^{(i)}, q_i, \psi_i) \mapsto q &:= \mathcal{S}_{i+1}\left(\frac{d}{dt}e^{(i)}, \mathfrak{B}_i(e^{(i)}, q_i, \psi_i)\right) \\ &= \mathcal{S}_{i+1}(e^{(i+1)}, q_{i+1}, \psi_{i+1}), \quad (16) \end{aligned}$$

and, finally,

$$\mathcal{S}_{r-1} : (e^{(r-1)}, q_{r-1}, \psi_{r-1}) \mapsto q := \mathfrak{B}_{r-1}(e^{(r-1)}, q_{r-1}, \psi_{r-1}).$$

We will inductively consider the closed loop as shown in Figure 5 and prove certain properties thereof. The basic idea is to reduce inductively the relative degree by taking the derivative of the output signal and using the corresponding switching logic \mathcal{S}_i with some additional input signals.

The following definition captures a desired property, “feasibility”, of the intermediate switching logic \mathcal{S}_i in the closed loop as in Figure 5. Afterwards we will show two things: 1) the feasibility assumptions $(\mathbf{F}_1) - (\mathbf{F}_9)$ from Section IV in combination with the design of the switching logic as in Section III ensure that each \mathcal{S}_i is feasible, and 2) feasibility of \mathcal{S}_i , $i = 1, \dots, r - 1$, yields that our main result, Theorem 4.1, holds.

Definition 6.1 (Feasibility of \mathcal{S}_i): Consider the closed loop from Figure 1a satisfying the well-posedness conditions from Theorem 5.3. For $i \in \{1, 2, \dots, r - 1\}$ and fixed reference signal y_{ref} consider the map $\mathcal{P}_i : u \mapsto e^{(i)}$ where $e := y - y_{\text{ref}}$ and y is the output of system (1) for the given input u and some

$$\mathfrak{F}_i^\varepsilon(t_0) \Rightarrow \forall t \in [t_0, t_1) : e^{(i)}(t) \in [\varphi_i^-(t), \varphi_i^+(t)], \quad (17a)$$

$$\mathfrak{C}_{q_i} \wedge \mathcal{W}_{\psi_i}^{r-i} \wedge \mathfrak{F}_i^{-,\varepsilon}(t_0) \Rightarrow \forall t \in [t_0, t_1) : e^{(i)}(t) \in [\varphi_i^-(t), \min\{\psi_i(t), -\lambda_i^-\}], \quad (17b)$$

$$\mathfrak{C}_{\neg q_i} \wedge \mathcal{W}_{\psi_i}^{r-i} \wedge \mathfrak{F}_i^{+,\varepsilon}(t_0) \Rightarrow \forall t \in [t_0, t_1) : e^{(i)}(t) \in [\max\{\psi_i(t), \lambda_i^+\}, \varphi_i^+(t)], \quad (17c)$$

$$\mathfrak{C}_{q_i} \wedge \mathcal{W}_{\psi_i}^{r-i} \wedge t_1 - t_0 > \Delta_i^- \Rightarrow \exists t \in [t_0, t_0 + \Delta_i^-] : e^{(i)}(t) \leq \min\{\psi_i(t), -\lambda_i^-\} - \varepsilon_i^+, \quad (17d)$$

$$\mathfrak{C}_{\neg q_i} \wedge \mathcal{W}_{\psi_i}^{r-i} \wedge t_1 - t_0 > \Delta_i^+ \Rightarrow \exists t \in [t_0, t_0 + \Delta_i^+] : e^{(i)}(t) \geq \max\{\psi_i(t), \lambda_i^+\} + \varepsilon_i^-, \quad (17e)$$

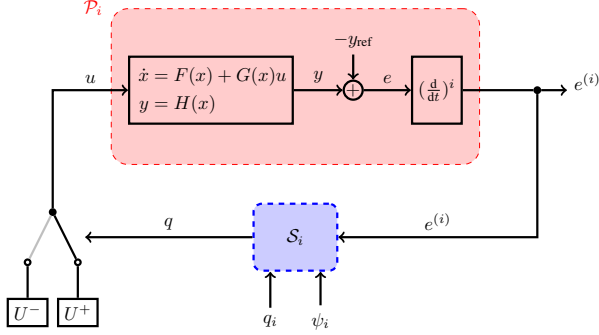

Fig. 5: Intermediate closed loop composed of system \mathcal{P}_i and switching logic \mathcal{S}_i utilized to prove the main result.

initial condition $x(0) = x^0 \in \mathbb{R}^n$. The switching logic \mathcal{S}_i (in the loop with \mathcal{P}_i) together with (q_i, ψ_i) are called *feasible with settling times* $\Delta_i^+, \Delta_i^- \in \mathbb{R}_{\geq 0}$ if, and only if, the following properties (i) and (ii) hold.

- (i) In the case $i < r - 1$: \mathcal{S}_{i+1} (in the loop with \mathcal{P}_{i+1}) together with $(q_{i+1}, \psi_{i+1}) = \mathfrak{B}_i(e^{(i)}, q_i, \psi_i)$ is feasible with settling times $\Delta_{i+1}^+, \Delta_{i+1}^- \in \mathbb{R}_{\geq 0}$, where $e^{(i)} : [0, \omega) \rightarrow \mathbb{R}$ denotes any solution of the closed loop \mathcal{S}_i and \mathcal{P}_i .
- (ii) For given (q_i, ψ_i) let q, e and $e^{(i)}$ be the corresponding solutions of the closed loop composed of $\mathcal{P}_i, \mathcal{S}_i$ and (8). Introduce the following (logical) abbreviations for some interval $[t_0, t_1) \subseteq \mathbb{R}_{\geq 0}$:

$$\begin{aligned} \mathfrak{F}_{[0, t_0)} &:= \left[\begin{array}{l} e, \dot{e}, \dots, e^{(r-1)} \text{ evolve within the} \\ \text{corresponding funnels } \mathcal{F}_j, \\ j = 0, \dots, r-1, \text{ on } [0, t_0) \end{array} \right], \\ \mathfrak{F}_{[t_0, t_1)}^{i-1} &:= \left[\begin{array}{l} e, \dot{e}, \dots, e^{(i-1)} \text{ evolve within the} \\ \text{corresponding funnels } \mathcal{F}_j, \\ j = 0, \dots, i-1, \text{ on } [t_0, t_1) \end{array} \right], \\ \mathfrak{C}_{q_i} &:= [q_i \text{ is constantly true on } [t_0, t_1)], \\ \mathfrak{C}_{\neg q_i} &:= [q_i \text{ is constantly false on } [t_0, t_1)], \\ \mathcal{W}_{\psi_i}^{r-i, \infty} &:= [\psi_i \in \mathcal{W}^{r-i, \infty}([t_0, t_1) \rightarrow \mathbb{R})], \\ \mathfrak{F}_i^{+,\varepsilon}(t_0) &:= \left[\begin{array}{l} e^{(i)}(t_0) \in [\max\{\psi_i(t_0), \lambda_i^+\} + \varepsilon_i^-, \\ \psi_i^+(t_0) - \varepsilon_i^+] \end{array} \right], \\ \mathfrak{F}_i^{-,\varepsilon}(t_0) &:= \left[\begin{array}{l} e^{(i)}(t_0) \in [\varphi_i^-(t_0) + \varepsilon_i^-, \\ \min\{\psi_i(t_0), -\lambda_i^-\} - \varepsilon_i^+] \end{array} \right], \\ \mathfrak{F}_i^\varepsilon(t_0) &:= [e^{(i)}(t_0) \in [\varphi_i^-(t_0) + \varepsilon_i^-, \varphi_i^+(t_0) - \varepsilon_i^+]]. \end{aligned}$$

Then for any interval $[t_0, t_1) \subseteq [0, \omega)$ for which $\mathfrak{F}_{[0, t_0)}$

and $\mathfrak{F}_{[t_0, t_1)}^{i-1}$ hold the implications (17a)–(17e) are true.

The feasibility property is best understood by having a look at Figure 6.

In order to prove that the switching logics \mathcal{S}_i are feasible we need the following technical result.

Lemma 6.2 (Overshoot bound, [14, Cor. 6.2]): Assume $\eta : [t_0, t_2] \rightarrow \mathbb{R}$ is twice differentiable and let a continuous $\psi^d : [t_0, t_1) \rightarrow \mathbb{R}$ be such that $\dot{\eta}(t) \leq \psi^d(t)$ for all $t \in [t_0, t_1) \subseteq [t_0, t_2]$. Furthermore, assume there exists $\lambda > 0$ such that $\dot{\eta}(t) \leq -\lambda$ for all $t \in [t_1, t_2]$. Then, for every absolutely continuous $\psi : [t_0, t_2] \rightarrow \mathbb{R}$ with essentially bounded derivative and $\varepsilon := \psi(t_0) - \eta(t_0) > 0$, it holds that $\eta(t) < \psi(t)$ for all $t \in [t_0, t_2]$ if

$$\varepsilon := \psi(t_0) - \eta(t_0) > (t_1 - t_0) \|\dot{\psi} - \psi^d\|_\infty + \frac{(\|\psi^d\|_\infty + \|\dot{\psi}\|_\infty)^2}{2\lambda}.$$

Lemma 6.3 (Feasibility of \mathcal{S}_i): Consider the closed loop from Figure 1a satisfying $(\mathbf{F}_1) - (\mathbf{F}_9)$. For some initial values $x^0 \in \mathbb{R}^n, \mathbf{q}^0 \in \{\text{true}, \text{false}\}^r$ let the maximally extended solution, including the internal signals (q_i, ψ_i) , be defined on $[0, \omega)$ (whose existence is guaranteed by Theorem 5.3). Then the internal switching logics $\mathcal{S}_i, i = 1, 2, \dots, r-1$ together with (q_i, ψ_i) and settling times Δ_i^+, Δ_i^- are feasible.

Proof: We prove this lemma by induction, beginning at $i = r-1$.

Step 1: Feasibility of \mathcal{S}_{r-1} .

Consider an interval $[t_0, t_1)$ for which $\mathfrak{F}_{[t_0, t_1)}^{r-2}$ and $\mathfrak{F}_{[0, t_0)}$ hold.

Step 1a: We show (17a) for $i = r-1$.

As shown in the proof of Theorem 5.3, ψ_{r-1} is piecewise-continuous with

$$\psi_{r-1} = \sum_{k \in \mathbb{N}} (\theta_k)_{[s_k, s_{k+1})}, \quad 0 = s_0 < s_1 < s_2 < \dots < \omega \quad (18)$$

and $\theta_k \in \mathcal{C}^0([0, \infty) \rightarrow \mathbb{R})$ fulfills either $\theta_k \in \{(\varphi_0^+)^{(r-1)}, (\varphi_1^+)^{(r-2)}, \dots, \dot{\varphi}_{r-2}^+\}$ if $q_{r-1}|_{[t_k, t_{k+1})} \equiv \text{true}$ or $\theta_k \in \{(\varphi_0^-)^{(r-1)}, (\varphi_1^-)^{(r-2)}, \dots, \dot{\varphi}_{r-2}^-\}$ otherwise. Invoking (\mathbf{F}_5) for $i = r-1$, the definition of \mathfrak{B}_{r-1} together with (8) yields the following implications for all $t \in [t_0, t_1)$:

$$\begin{aligned} e^{(r-1)}(t) \geq \varphi_{r-1}^+(t) - \varepsilon_{r-1}^+ &\Rightarrow u(t) = U^-, \\ e^{(r-1)}(t) \leq \varphi_{r-1}^-(t) + \varepsilon_{r-1}^- &\Rightarrow u(t) = U^+. \end{aligned} \quad (19)$$

Invoking $\mathfrak{F}_{r-1}^\varepsilon(t_0)$ we may assume existence of $\hat{t} \in [t_0, t_1)$ such that $e^{(r-1)}(t) \in [\varphi_{r-1}^-(t) + \varepsilon_{r-1}^-, \varphi_{r-1}^+(t) - \varepsilon_{r-1}^+]$ for all $t \in [t_0, \hat{t}]$. Due to $\mathfrak{F}_{[t_0, t_1)}^{r-2}$ and $\mathfrak{F}_{[0, t_0)}$ it holds that $(y(t), \dot{y}(t), \dots, y^{(r-1)}(t)) \in \Phi_t^{y_{\text{ref}}}$ and, invoking (\mathbf{F}_1) , $z(t) \in Z_t^{y_{\text{ref}}}$ for all $t \in [0, \hat{t}]$. Now if $u(t) = U^-$ for some $t \in [t_0, \hat{t}]$

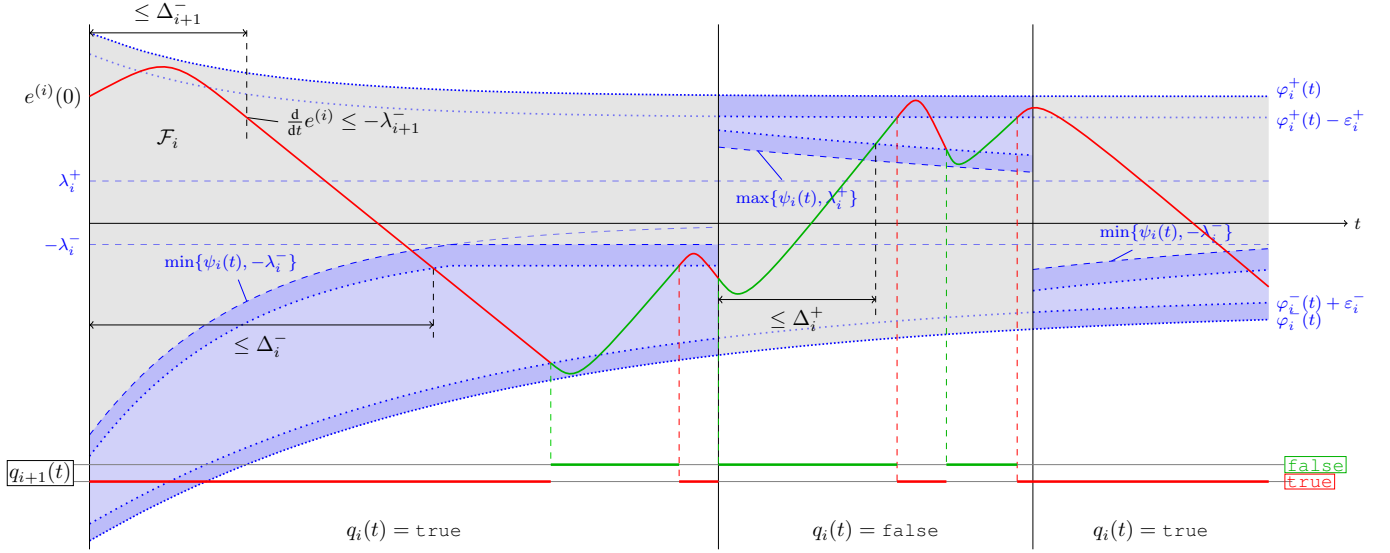

Fig. 6: An illustration for understanding the feasibility property of the switching logic \mathcal{S}_i together with (q_i, ψ_i) in the intermediate closed loop as shown in Figure 5. Condition (17a) ensures that $e^{(i)}$ remains within the funnel \mathcal{F}_i (provided the initial value $e^{(i)}(t_0)$ was safely contained in \mathcal{F}_i), conditions (17b) and (17c) ensure that $e^{(i)}$ remains within the blue shaded regions as long as initially $e^{(i)}(t_0)$ was safely contained in the corresponding region; finally, conditions (17d) and (17e) ensure that within a time span of length at most Δ_i^\pm the signal $e^{(i)}$ reaches the blue shaded region. Additionally, the output q_{i+1} of the block \mathcal{B}_i is indicated.

then

$$e^{(r)}(t) = -y_{\text{ref}}^{(r)}(t) + f(y(t), \dot{y}(t), \dots, y^{(r-1)}(t), z(t)) \\ + g(y(t), \dot{y}(t), \dots, y^{(r-1)}(t), z(t)) U^-$$

and (\mathbf{F}_9) yields $e^{(r)}(t) \leq -\lambda_r^- \stackrel{(\mathbf{F}_8)}{<} \dot{\varphi}_{r-1}^+$ and, analogously, $u(t) = U^+$ implies $e^{(r)}(t) \geq \lambda_r^+ \stackrel{(\mathbf{F}_8)}{>} \dot{\varphi}_{r-1}^-$. Whence, (19) yields that the time-varying region

$$\mathcal{F}_{r-1}^\varepsilon := \left\{ (t, e^{(r-1)}) \in [t_0, t_1) \times \mathbb{R} \mid \begin{array}{l} \varphi_{r-1}^-(t) + \varepsilon_{r-1}^- \leq e^{(r-1)} \\ \leq \varphi_{r-1}^+(t) - \varepsilon_{r-1}^+ \end{array} \right\} \\ \subseteq \mathcal{F}_{r-1}$$

is positively invariant for $e^{(r-1)}$ on $[t_0, t_1)$, i.e. the graph $t \mapsto (t, e^{(r-1)}(t))$ remains within $\mathcal{F}_{r-1}^\varepsilon$ for $t_0 \leq t \leq t_1$ if $(t_0, e^{(r-1)}(t_0)) \in \mathcal{F}_{r-1}^\varepsilon$.

Step 1b: We show (17b) and (17c) for $i = r - 1$.

It suffices to show (17b) because (17c) can be shown analogously. Invoking $\mathcal{C}_{q_{r-1}}$, the definition of the switching logic of block \mathcal{B}_{r-1} together with (8) yields immediately for all $t \in [t_0, t_1)$ the implications

$$e^{(r-1)}(t) \geq \psi_{r-1}(t) - \varepsilon_{r-1}^+ \Rightarrow u(t) = U^-, \\ e^{(r-1)}(t) \leq \varphi_{r-1}^-(t) + \varepsilon_{r-1}^- \Rightarrow u(t) = U^+.$$

Analogously as in Step 1 and invoking $\mathcal{W}_{\psi_{r-1}}^{1, \infty}$, $u(t) = U^-$ implies

$$e^{(r)}(t) \leq -\lambda_r^- \stackrel{(\mathbf{F}_8)}{<} \min\{\dot{\varphi}_{r-1}^+(t), \ddot{\varphi}_{r-2}^+(t), \dots, (\varphi_0^+)^{(r)}(t)\} \\ \stackrel{(18)}{\leq} \dot{\psi}(t)$$

and $u(t) = U^+$ implies

$$e^{(r)}(t) \geq \lambda_r^+ \stackrel{(\mathbf{F}_8)}{>} \dot{\varphi}_{r-1}^-(t).$$

Hence, the region

$$\{ (t, e^{(r-1)}) \mid t \in [t_0, t_1), e^{(r-1)} \in [\varphi_{r-1}^-(t), \psi(t)] \}$$

is positively invariant for $e^{(r-1)}$ on $[t_0, t_1)$ and (17b) for $i = r - 1$ is shown.

Step 1c: We show (17d) and (17e) for $i = r - 1$. Again it suffices to show (17d) because (17e) can be shown analogously. Choose a minimal $\hat{t} \in [t_0, t_1)$ such that $e^{(r-1)}(\hat{t}) \leq \min\{\psi_{r-1}(\hat{t}), -\lambda_{r-1}^- - \varepsilon_{r-1}^+\}$ if it exists and $\hat{t} = t_1$ otherwise. Seeking a contradiction assume $\hat{t} - t_0 > \Delta_{r-1}^-$. In particular, $\hat{t} > t_0$ and therefore $e^{(r-1)}(\hat{t}) \geq \min\{\psi(\hat{t}), -\lambda_{r-1}^- - \varepsilon_{r-1}^+\}$. Because of $\mathcal{C}_{q_{r-1}}$ the switching logic \mathcal{S}_{r-1} yields $q(t) = \text{true}$ on $[t_0, \hat{t})$, hence $u(t) = U^-$ on $[t_0, \hat{t})$ and as in Step 1a

$$\forall t \in [t_0, \hat{t}): e^{(r)}(t) \leq -\lambda_r^-. \quad (20)$$

Therefore, we arrive at the following contradiction,

$$\min\{\psi(\hat{t}), -\lambda_{r-1}^- - \varepsilon_{r-1}^+\} \leq e^{(r-1)}(\hat{t}) \\ \stackrel{(20)}{\leq} e^{(r-1)}(t_0) - \lambda_r^-(\hat{t} - t_0) \stackrel{\text{Step 1a}}{\leq} \|\varphi_{r-1}^+\|_\infty - \lambda_r^- \Delta_{r-1}^- \\ \stackrel{(\mathbf{F}_6)}{\leq} \|\varphi_{r-1}^+\|_\infty - (\|\varphi_{r-1}^+\|_\infty + \|\varphi_{r-1}^-\|_\infty) \leq \varphi_{r-1}^-(\hat{t}) \\ \stackrel{(\mathbf{F}_5), (18)}{<} \min\{\psi(\hat{t}), -\lambda_{r-1}^- - \varepsilon_{r-1}^+\}.$$

Step 2: We show that feasibility of \mathcal{S}_{i+1} implies feasibility of \mathcal{S}_i .

Consider an interval $[t_0, t_1)$ for which $\mathfrak{F}_{[t_0, t_1)}^{i-1}$ and $\mathfrak{F}_{[0, t_0)}$ hold and assume \mathcal{S}_{i+1} is feasible.

Step 2a: We show (17a).

Seeking a contradiction, assume that $e^{(i)}$ leaves the funnel \mathcal{F}_i , i.e. there exists a minimal $s_1 \in (t_0, t_1)$ such that $e^{(i)}(s_1) = \varphi_i^+(s_1)$ or $e^{(i)}(s_1) = \varphi_i^-(s_1)$. It suffices to consider the first case, the second case follows analogously.

The choice of s_1 together with $\mathfrak{F}_{[0,t_0]}$ implies $\mathfrak{F}_{[0,s_1]}^i$, hence feasibility of \mathcal{S}_{i+1} together with (\mathbf{F}_3) yields $\mathfrak{F}_{[0,s_1]}^{i+1}$. By definition, feasibility of \mathcal{S}_{i+1} also implies feasibility of $\mathcal{S}_{i+2}, \dots, \mathcal{S}_{r-1}$, so we can repeat the previous argument to conclude that $\mathfrak{F}_{[0,s_1]}$ holds. In particular, the implications (17) for the index $i+1$ are true for any interval $[s_0, s_1]$ with $0 \leq s_0 < s_1$.

From $\mathfrak{F}_i^\varepsilon(t_0)$ it follows that there exists $s_0 \in [t_0, s_1]$ such that $e^{(i)}(s_0) = \varphi_i^+(s_0) - \varepsilon_i^+$ and $\varepsilon_i^+ \geq \varphi_i^+(s) - e^{(i)}(s) > 0$ for all $s \in [s_0, s_1]$. The switching logic \mathcal{S}_i ensures (independently of q_i and ψ_i , due to (18) and (\mathbf{F}_5)) that $\psi_{i+1} = \dot{\varphi}_i^+ \in \mathcal{W}^{r-(i+1)}$ and $q_{i+1} \equiv \text{true}$ on $[s_0, s_1]$, i.e. $\mathcal{W}_{\psi_{i+1}}^{r-(i+1)}$ and $\mathcal{C}_{q_{i+1}}$ are true for the interval $[s_0, s_1]$.

In the following we show that $e^{(i+1)}(s) > \min\{\psi_{i+1}(s), -\lambda_{i+1}^-\} - \varepsilon_{i+1}^+$ for all $s \in [s_0, s_1]$. Seeking a contradiction, assume the contrary for some $s \in [s_0, s_1]$, then feasibility of \mathcal{S}_{i+1} together with (17b) yield that $e^{(i+1)}(t) \leq \psi_{i+1}(t) = \dot{\varphi}_i^+(t)$ for all $t \in [s, s_1]$. In particular, $\frac{d}{dt}(\varphi_i^+ - e^{(i)})(t) \geq 0$ on $[s, s_1]$, i.e. $\varphi_i^+ - e^{(i)}$ is monotonically increasing on $[s, s_1]$, which contradicts $\varphi_i^+(s) - e^{(i)}(s) > 0 = \varphi_i^+(s_1) - e^{(i)}(s_1)$.

Hence $e^{(i+1)}(s) > \min\{\psi_{i+1}(s), -\lambda_{i+1}^-\} - \varepsilon_{i+1}^+$ and the switching logic \mathcal{S}_{i+1} yields $q_{i+2} \equiv \text{true}$ on $[s_0, s_1]$ and $\psi_{i+1} = \dot{\varphi}_i^- \in \mathcal{W}^{r-(i+1), \infty}$ if $i < r-2$ and $q_r := q \equiv \text{true}$ on $[s_0, s_1]$ if $i = r-2$. Therefore, (17d) and (17b) for \mathcal{S}_{i+2} (if $i < r-2$) or (\mathbf{F}_8) and (\mathbf{F}_9) (if $i = r-2$, see also the arguments from Step 1a) ensure that $e^{(i+2)}(t) \leq -\lambda_{i+2}^-$ for all $t \in [s_0 + \Delta_{i+2}^-, s_1]$.

In summary, we have shown that $e^{(i+1)}(t) \leq \varphi_{i+1}^+(t)$ for all $t \in [s_0, s_0 + \Delta_{i+2}^-] \cap [s_0, s_1]$ and $e^{(i+2)}(t) \leq -\lambda_{i+2}^-$ for all $t \in [s_0 + \Delta_{i+2}^-, s_1]$. Invoking

$$\begin{aligned} \varphi_i^+(s_0) - e^{(i)}(s_0) &= \varepsilon_i^+ \\ &\stackrel{(\mathbf{F}_7)}{>} \Delta_{i+2}^- \|\dot{\varphi}_i^+ - \varphi_{i+1}^+\| + \frac{(\|\dot{\varphi}_i^+\|_\infty + \|\varphi_{i+1}^+\|_\infty)^2}{2\lambda_{i+2}^-} \end{aligned}$$

Lemma 6.2 then implies

$$\forall t \in [s_0, s_1]: \quad e^{(i)}(t) < \varphi_i^+(t),$$

whence the sought contradiction $0 = \varphi_0^+(s_1) - e(s_1) > 0$.

Step 2b: We show (17b) and (17c).

These properties can be shown analogously as in Step 2a by replacing the upper bound φ_i^+ by ψ_i if $q_i \equiv \text{true}$ or by replacing the lower bound φ_i^- by ψ_i if $q_i \equiv \text{false}$.

Step 2c: We show (17d) and (17e).

We only show (17d) because (17e) follows analogously. Choose a minimal $\hat{t} \in [t_0, t_1]$ such that $e^{(i)}(\hat{t}) \leq \min\{\psi_i(\hat{t}), -\lambda_i^-\} - \varepsilon_i^+$ if it exists and $\hat{t} = t_1$ otherwise. If $\hat{t} \leq t_0 + \Delta_{i+1}^+ + \frac{\|\varphi_i^+\|_\infty + \|\varphi_i^-\|_\infty}{\lambda_{i+1}^+}$ then, by (\mathbf{F}_6) , $\hat{t} \leq t_0 + \Delta_i^+$ and there is nothing to show; therefore, seeking a contradiction, assume the contrary. Note that then $t_0 < \hat{t}$ and hence $e^{(i)}(\hat{t}) \geq \min\{\psi_i(\hat{t}), -\lambda_i^-\} - \varepsilon_i^+$. If \mathcal{C}_{q_i} and $\mathcal{W}_{\psi_i}^{r-i}$ hold then it follows that the switching logic \mathcal{S}_i produces $q_{i+1} \equiv \text{true}$ and $\psi_{i+1} = \dot{\psi}_i \in \mathcal{W}^{r-(i+1)}$ on $[t_0, \hat{t}]$. Therefore, (17b) and (17d) of \mathcal{S}_{i+1} imply that $e^{(i+1)}(t) \leq -\lambda_{i+1}^-$ on $[t_0 + \Delta_{i+1}^-, \hat{t}]$.

Hence we arrive at the sought contradiction

$$\begin{aligned} &\min\{\psi_i(\hat{t}), -\lambda_i^-\} - \varepsilon_i^+ = e^{(i)}(\hat{t}) \\ &\leq e^{(i)}(t_0 + \Delta_{i+1}^-) - (\hat{t} - (t_0 + \Delta_{i+1}^-))\lambda_{i+1}^- \\ &< \|\varphi_i^+\|_\infty - (\|\varphi_i^+\|_\infty + \|\varphi_i^-\|_\infty) \leq \varphi_i^-(\hat{t}) \\ &\stackrel{(\mathbf{F}_5)}{<} \max\{\psi_i(\hat{t}), -\lambda_i^-\} - \varepsilon_i^+, \end{aligned}$$

where we used $e^{(i)}(t_0 + \Delta_{i+1}^-) \leq \varphi_i^+(t_0 + \Delta_{i+1}^-) < \|\varphi_i^+\|_\infty$ which follows from Step 2a. ■

We are now able to prove the main result.

Proof of Theorem 4.1: Due to Theorem 5.3 there exists a maximally extended solution for the error signal $e \in \mathcal{C}^{r-1}([0, \omega] \rightarrow \mathbb{R})$, the switching signal $q : [0, \omega] \rightarrow \{\text{true}, \text{false}\}$ and the internal signals $\psi_i : [0, \omega] \rightarrow \mathbb{R}$, $q_i : [0, \omega] \rightarrow \{\text{true}, \text{false}\}$, $i = 1, \dots, r-1$. Furthermore, Lemma 6.3 shows that the intermediate switching logics \mathcal{S}_i in connection with (ψ_i, q_i) are feasible in the sense of Definition 6.1.

Step 1: We show $e^{(i)}(t)$ remains within the corresponding funnels on $[0, \omega]$.

For $i = 0$ this follows analogously as in Step 1a (if $r = 1$) or Step 2a (if $r > 1$) in the proof of Lemma 6.3. Inductively, the feasibility of \mathcal{S}_i together with (\mathbf{F}_3) implies $e^{(i)}(t) \in [\varphi_i^-(t), \varphi_i^+(t)]$ for all $t \in [0, \omega]$. In particular, (\mathbf{F}_4) implies that $e^{(i)}$, $i = 0, 1, \dots, r-1$, are bounded on $[0, \omega]$.

Step 2: We show $\omega = \infty$.

Seeking a contradiction, assume $\omega < \infty$, then the continuous signals $y_{\text{ref}}^{(i)}$, $i \in \{0, \dots, r-1\}$, are bounded on the compact interval $[0, \omega]$. Hence boundedness of $e^{(i)}$ as shown in Step 1 yields that $y^{(i)}$, $i = 0, \dots, r-1$ are bounded on $[0, \omega]$. By (6) in (\mathbf{F}_1) it follows that system (5) or, equivalently, (1) can not have a finite escape time. Therefore, $\omega < \infty$ is only possible if the switchings of q_1, q_2, \dots, q_{r-1} or q accumulate as $t \rightarrow \omega$.

Inductively, we will first show that each signal q_i , $i = 1, \dots, r-1$, can not have an accumulation of switching times as $t \rightarrow \omega$. Seeking a contradiction, assume that the switching times of q_1 form an increasing sequence $(t_k)_{k \in \mathbb{N}}$ with $t_k \rightarrow \omega$. This implies that $e(t_k) = \varphi_0^+(t_k) - \varepsilon_0^+$ and $e(t_{k+1}) = \varphi_0^-(t_{k+1}) + \varepsilon_0^-$ for either all even $k \in \mathbb{N}$ or all odd $k \in \mathbb{N}$, without loss of generality consider $k \in \mathbb{N}$ even in the following. Note that $t_{k+1} - t_k \rightarrow 0$ as $k \rightarrow \infty$.

Due to compactness of the interval $[0, \omega]$ and (\mathbf{F}_5) there exists $\delta > 0$ and $\varepsilon > 0$ such that $\varphi_0^+(t) - \varepsilon_0^+ - (\varphi_0^-(s) + \varepsilon_0^-) \geq \delta$ for all $s, t \in [0, \omega]$ with $|s - t| < \varepsilon$. Hence $e(t_k) - e(t_{k+1}) \geq \delta$ for all even k sufficiently large. Then the Mean Value Theorem yields the existence of $\hat{t}_k \in [t_k, t_{k+1}]$ such that $\dot{e}(\hat{t}_k) = \frac{e(t_{k+1}) - e(t_k)}{t_{k+1} - t_k} \leq -\delta / (t_{k+1} - t_k)$. Since $t_{k+1} - t_k \rightarrow 0$ as $k \rightarrow \infty$ this contradicts boundedness of \dot{e} . Therefore, the switching times of q_1 do not accumulate as $t \rightarrow \omega$. In particular, there exists $\bar{t} \in [0, \omega)$ such that q_1 is constant on $[\bar{t}, \omega)$. Assuming for the inductive argument that q_1, q_2, \dots, q_i are constant on $[\bar{t}, \omega)$ for some $\bar{t} \in [0, \omega)$, analogous arguments show that also q_{i+1} cannot have an accumulation of switching times toward ω .

Finally, to show that q does not have an accumulation of switching times as $t \rightarrow \omega$, we first have to observe that boundedness of $y, \dot{y}, \dots, y^{(r-1)}$, boundedness of z and

(F₁₀) $\Delta_r^+ \geq \tau_q$, $\Delta_r^- \geq \tau_q$ and, for all $t \geq 0$, $\varepsilon_{r-1}^+ > (\tau_e + \tau_d)E_{[t, t+\tau_e+\tau_q]}^+$ and $\varepsilon_{r-1}^- > (\tau_e + \tau_d)E_{[t, t+\tau_e+\tau_q]}^-$, where

$$E_{[t, t+\tau_e+\tau_q]}^+ := \sup_{\substack{s \in [t, t+\tau_e+\tau_q], z_s \in Z_s^{y_{\text{ref}}^+} \\ (y_s^0, y_s^1, \dots, y_s^{r-1}) \in \Phi_s^{y_{\text{ref}}^+}}} -y_{\text{ref}}^{(r)}(s) + f(y_s^0, y_s^1, \dots, y_s^{r-1}, z_s) + g(y_s^0, y_s^1, \dots, y_s^{r-1}, z_s)U^+ - \dot{\varphi}_{r-1}^+(s),$$

$$E_{[t, t+\tau_e+\tau_q]}^- := \sup_{\substack{s \in [t, t+\tau_e+\tau_q], z_s \in Z_s^{y_{\text{ref}}^-} \\ (y_s^0, y_s^1, \dots, y_s^{r-1}) \in \Phi_s^{y_{\text{ref}}^-}}} y_{\text{ref}}^{(r)}(s) - f(y_s^0, y_s^1, \dots, y_s^{r-1}, z_s) - g(y_s^0, y_s^1, \dots, y_s^{r-1}, z_s)U^- + \dot{\varphi}_{r-1}^-(s),$$

boundedness of u implies by continuity of f and g in (5) that also $y^{(r)}$ is bounded on $[0, \omega)$. Hence the same arguments as above also show that q has no accumulation of switching times.

Altogether this shows $\omega = \infty$ and, in particular, q has locally finitely many switches. ■

VII. TIME DELAYS IN THE FEEDBACK LOOP

An analysis of the arguments carried out in Section VI reveals that the settling times play the role of a “time delay” in the intermediate closed loop with \mathcal{S}_i as shown in Figure 5, i.e. only after the settling time Δ_{i+1}^\pm has passed we know that the corresponding signal $e^{(i)}$ decreases/increases fast enough such that the funnel \mathcal{F}_i cannot be left. This behavior made it necessary to introduce the safety distances ε_i^\pm and (F₇). Hence this approach already includes some kind of time delay; we will formalize this intuition in this section.

Due to the normal form induced by (F₁) the error signal $e^{(r)}$ can be directly influenced by the choice of the input signal as shown in Step 1a of the proof of Lemma 6.3. Hence the intermediate closed loop driven by \mathcal{S}_{r-1} has no inherent time delay, i.e. $\Delta_r^\pm = 0$. For this reason ε_{r-1}^+ and ε_{r-1}^- can be set to zero and the main result in Theorem 4.1 still holds. However, in practical applications, there might be a time delay between the moment the corresponding switch-trigger is hit and the moment the switching logic reacts on this event. Furthermore, there might be an additional time delay between the switching logic and the actual input signal. Reasons for these time delays might be that the (digital) controller is connected via a communication network with delays, the test whether the switching triggers are hit might be sampled, or the switching logic itself needs some time to evaluate the new input signal. Altogether a feedback loop with (constant) time delays τ_e and τ_q as shown in Figure 7 is a more realistic setup.

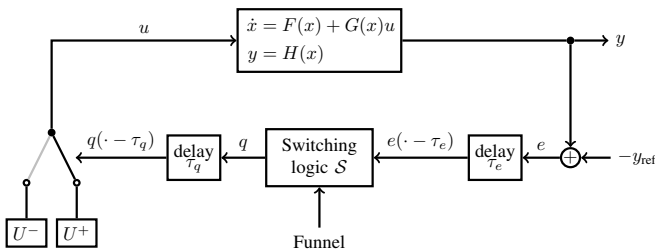

Fig. 7: The closed loop with additional time delays τ_e for the error signal e and τ_q for the switching signal q .

With only a slight change of the feasibility assumption (F₇) into

$$(\mathbf{F}_7^{\tau_e}) \quad \varepsilon_i^+ > \frac{(\Delta_{i+2}^+ + \tau_e)\|\dot{\psi} - \varphi_{i+1}^+\|_\infty + \frac{(\|\dot{\psi}\|_\infty + \|\varphi_{i+1}^+\|_\infty)^2}{2\lambda_{i+2}^-}}{\lambda_{i+2}^-}, \quad \psi \in \{\varphi_i^+, \dot{\varphi}_{i-1}^+, \dots, (\varphi_0^+)^{(i)}\},$$

$$i = 0, 1, \dots, r-2, \text{ and}$$

$$\varepsilon_i^- > \frac{(\Delta_{i+2}^- + \tau_e)\|\dot{\psi} - \varphi_{i+1}^-\|_\infty + \frac{(\|\dot{\psi}\|_\infty + \|\varphi_{i+1}^-\|_\infty)^2}{2\lambda_{i+2}^+}}{\lambda_{i+2}^+}, \quad \psi \in \{\varphi_i^-, \dot{\varphi}_{i-1}^-, \dots, (\varphi_0^-)^{(i)}\},$$

$$i = 0, 1, \dots, r-2,$$

and the new feasibility assumption (F₁₀) we obtain the same result as in Theorem 4.1 even when considering time delays.

Theorem 7.1 (Bang-bang funnel controller & time delays): Consider the nonlinear system (1) and the bang-bang funnel controller as in Section III with additional time delays as shown in Figure 7. Let the feasibility assumptions (F₁) – (F₉) with (F₇) replaced by (F₇^{τ_e}) and the additional feasibility assumption (F₁₀) be satisfied. Then the bang-bang funnel controller works, i.e. there exists a global solution of the closed loop such that q has locally finitely many switches and the error and its derivatives evolve within the corresponding funnels, i.e. $e^{(i)}(t) \in [\varphi_i^-(t), \varphi_i^+(t)]$ for all $t \geq 0$ and all $i = 0, 1, \dots, r-1$.

Proof: The well-posedness result from Theorem 5.3 remains valid without any modification. The remaining proof is very much the same as the proof of Theorem 4.1 in Section VI, the only difference is that in (17d) and (17e) the settling times Δ_i^\pm are replaced by $\Delta_i^\pm + \tau_e$ and in Step 1 of the proof of Lemma 6.3 the following implications have to be taken into account

$$e^{(r-1)}(t_0) = \varphi_{r-1}^+(t_0) - \varepsilon_{r-1}^+$$

$$\Rightarrow \forall t \in [t_0, t_0 + \tau_e + \tau_q] : e^{(r-1)}(t) \leq \varphi_{r-1}^+(t),$$

$$e^{(r-1)}(t_0) = \varphi_{r-1}^-(t_0) + \varepsilon_{r-1}^-$$

$$\Rightarrow \forall t \in [t_0, t_0 + \tau_e + \tau_q] : e^{(r-1)}(t) \geq \varphi_{r-1}^-(t).$$

Note that, in general, the expressions for $E_{[t, t+\tau_e+\tau_q]}^\pm$ cannot be simplified with the help of (F₉) because the latter is used to establish a lower bound for $|e^{(r)}|$ while the former uses an upper bound for $|e^{(r)}|$.

Remark 7.2 (Feasibility and time delays): A similar statement as in Theorem 4.2 is in general not possible when time delays are present, i.e. given some funnel for the error fulfilling (F₄), (F₅) and time delays τ_e, τ_d it is not always possible to construct funnel boundaries such that the feasibility conditions are fulfilled. However, the feasibility construction according to the proof of Theorem 4.2 reveals the maximal size of the “settling times” Δ_r^\pm which give an upper bound on the time delay τ_q . In particular, it gives a guideline on the necessary sampling rate of the switching logic.

VIII. RELATIVE DEGREE FOUR SIMULATION

In this section we carry out simulations for a relative degree four example, where we take time delays due to the time sampling into account. To circumvent the problem of competing control objectives as highlighted in Remark 4.3 and also to simplify the feasibility assumptions we consider constant funnel boundaries; in particular, the transient behavior is not in the focus of this simulation. As an academic example we consider the following nonlinear system

$$\begin{aligned} y^{(4)} &= z \ddot{y}^2 + e^z u, \quad y^{(i)}(0) = y_{\text{ref}}^{(i)}(0), \quad i = 0, \dots, 3, \\ \dot{z} &= z(a - z)(z + b) - cy, \quad z(0) = 0, \end{aligned} \quad (21)$$

where $a, b, c \in \mathbb{R}$ are parameters of which only the following bounds are known: $0 < a \leq 0.1$, $0 < b \leq 0.1$, $|c| \leq 0.01$. Note that the system with zero input and for $c > 0$ will exhibit finite escape time if $\ddot{y}(0) \neq 0$. As reference signal we choose $y_{\text{ref}}(t) = 5 \sin(t)$ which satisfies (\mathbf{F}_2) . We choose the funnels, the bang-bang funnel controller parameters and the settling times as follows:

$$\begin{aligned} \varphi_0^+ &= -\varphi_0^- \equiv 1, & \varepsilon_0^+ &= \varepsilon_0^- = 0.9, \\ \varphi_1^+ &= -\varphi_1^- \equiv 0.5, & \varepsilon_1^+ &= \varepsilon_1^- = 0.1, \\ \varphi_2^+ &= -\varphi_2^- \equiv 0.5, & \varepsilon_2^+ &= \varepsilon_2^- = 0.1, \\ \varphi_3^+ &= -\varphi_3^- \equiv 4.5, & \varepsilon_3^+ &= \varepsilon_3^- = 0.1, \\ & & \Delta_0^+ &= \Delta_0^- = \infty, \\ \lambda_1^+ &= \lambda_1^- = 0, & \Delta_1^+ &= \Delta_1^- = \Delta_0^\pm / 2 = \infty, \\ \lambda_2^+ &= \lambda_2^- = 0.2, & \Delta_2^+ &= \Delta_2^- = 0.4, \\ \lambda_3^+ &= \lambda_3^- = 4, & \Delta_3^+ &= \Delta_3^- = 0.1, \\ \lambda_4^+ &= \lambda_4^- = 102, & \Delta_4^+ &= \Delta_4^- = 0.0001. \end{aligned}$$

Note that for simplicity we have chosen constant funnels, i.e. we only illustrate the “steady state” performance and not the transient behavior. In particular, the internal signals $\psi_1, \psi_2, \dots, \psi_{r-1}$ of the switching logic are all identical zero. It is not difficult to verify that the feasibility conditions (\mathbf{F}_3) - (\mathbf{F}_8) are fulfilled. Note that these parameters do not depend on the actual system. The only control parameters which depend on the system are U^+ and U^- . In order to choose feasible values for U^+ and U^- we have to find bounds for the terms in (\mathbf{F}_9) . First observe that, for all $t \geq 0$,

$$\Phi_t^{y_{\text{ref}}} \subseteq \left\{ \begin{pmatrix} y_0 \\ y_1 \\ y_2 \\ y_3 \end{pmatrix} \in \mathbb{R}^4 \mid \begin{array}{ll} |y_0| \leq 6, & |y_1| \leq 5.5, \\ |y_2| \leq 5.5, & |y_3| \leq 9.5 \end{array} \right\}.$$

With $Z_0 = [-0.5, 0.5]$ it can now easily be verified that

$$Z_t^{y_{\text{ref}}} \subseteq [-0.5, 0.5] \quad \forall t \geq 0.$$

Hence, for all $t \geq 0$, $(y_t^0, y_t^1, y_t^2, y_t^3) \in \Phi_t^{y_{\text{ref}}}$ and $z_t \in Z_t^{y_{\text{ref}}}$,

$$|z_t (y_t^3)^2| \leq 45.125 \quad \text{and} \quad e^{z_t} \geq e^{-0.5} \geq 0.6.$$

Altogether this guarantees that

$$U^+ = -U^- := 254 \geq \frac{102 + 5 + 45.125}{0.6} \approx 253.54$$

is feasible (in the sense of (\mathbf{F}_9)) for the bang-bang funnel controller. Finally for carrying out the simulation we have to check

the maximal step size in view of the time delay introduced by the sampled time axis. The feasibility assumption (\mathbf{F}_{10}) yields the following upper bound for the simulation step size h

$$\begin{aligned} h &\leq \min \left\{ \Delta_4^\pm, \frac{\varepsilon_3^\pm}{\|y_{\text{ref}}^{(4)}\|_\infty + \|z(y^{(3)})^2\|_\infty + \|e^z\|_\infty U^+ + \|\dot{\varphi}_3^\pm\|_\infty} \right\} \\ &= \min \left\{ 10^{-4}, \frac{0.1}{5 + 45.125 + e^{0.5} 300 + 0} \right\} = 10^{-4}. \end{aligned}$$

The simulation was carried out with the step size $h = 10^{-4}$ and the parameters of (21) are

$$a = 0.09, \quad b = 0.05, \quad c = 0.008.$$

The overall tracking accuracy is shown in Figure 8, which clearly shows that the error follows the reference signal within the specified error bounds (given by φ_0^\pm).

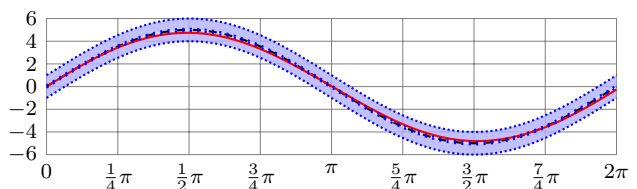

Fig. 8: The bang-bang funnel controller applied to the nonlinear relative degree four system (21): The output y — follows the reference signal - - within the prespecified bounds φ_0^\pm ····, the safety distance ε_0^\pm is shown as ····.

The behavior of the bang-bang funnel controller in detail is shown in Figure 9 where the error $e(t)$ and its derivatives $\dot{e}(t)$, $\ddot{e}(t)$, $\ddot{\ddot{e}}(t)$ for $t \in [0, 2\pi]$ are plotted. In addition the internal switching variables $q_1(t)$, $q_2(t)$ and $q_3(t)$ are shown as well as the resulting (external) switching signal $q(t)$ which determines directly $u(t)$ via

$$u(t) = \begin{cases} U^-, & \text{if } q(t) = \text{true}, \\ U^+, & \text{if } q(t) = \text{false}, \end{cases}$$

The switching frequency of the input $u(\cdot)$ is locally up to 10^3 Hz and might seem high. However, it should be noted that a relative degree four model in reality could arise from modeling a mechanical system (relative degree two) in combination with a model of the electro-mechanical actuator (relative degree two). Since the electrical input is often realized with a digital controller, a frequency of 10^3 Hz should be no problem.

IX. CONCLUSIONS

We have presented a novel control design for tracking of arbitrary reference signals and for nonlinear systems of which only the relative degree $r > 0$ and the sign of the “high frequency gain” is known. The controller uses only two control values (hence the name “bang-bang” funnel controller) and the switching logic is easily implementable. Our proposed controller assumes knowledge of the first $r - 1$ derivatives of the error and can therefore be seen as a (partial) state feedback controller. Due to the technicalities of the proof it is at the moment not clear whether adding a simple observer

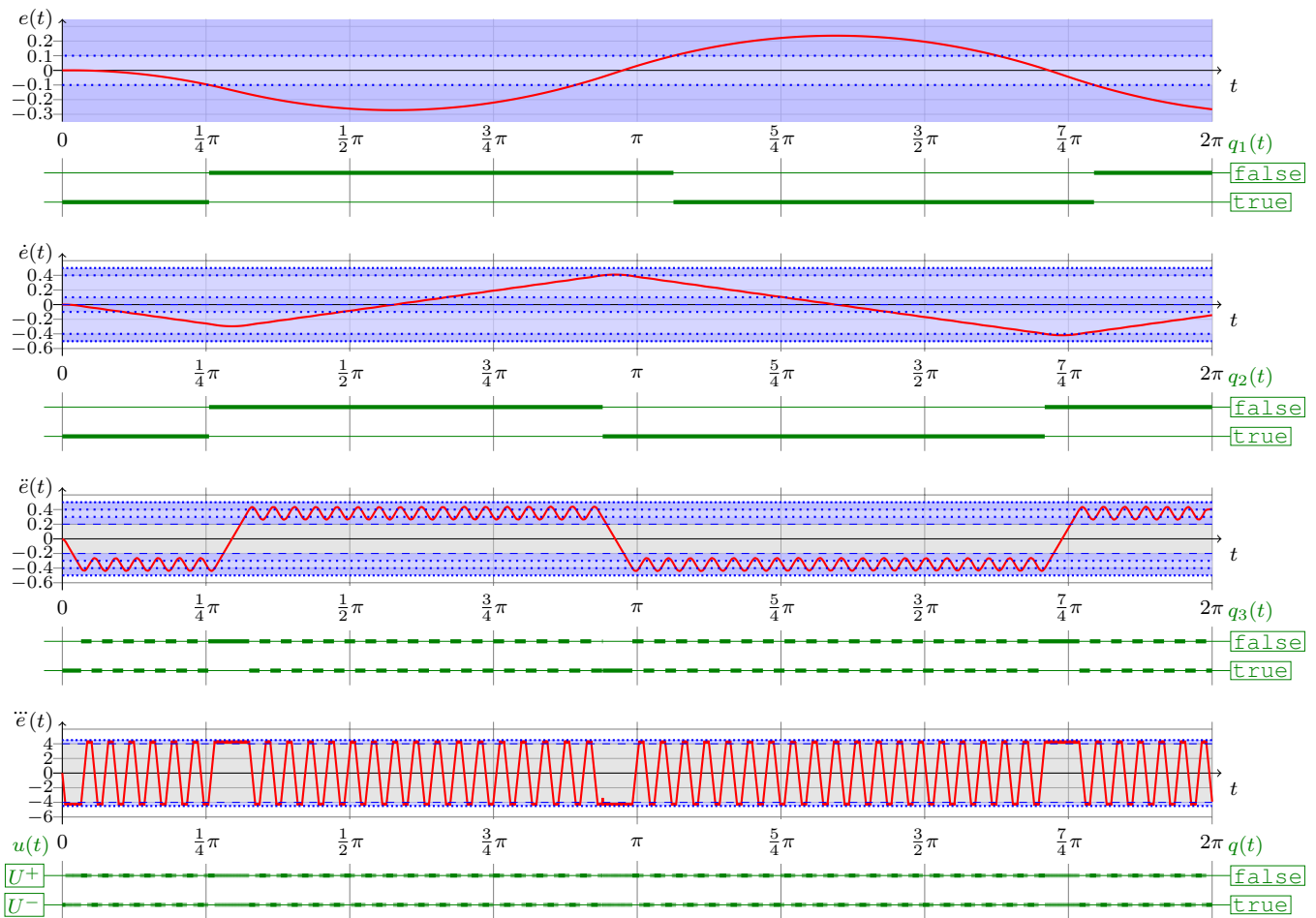

Fig. 9: The error and its derivatives — with corresponding switching variables —. The funnel boundaries are drawn as \cdots (note that the funnel boundaries $\varphi_0^\pm \equiv 1$ are not in the picture), the safety distances are shown as \cdots .

to approximate the derivatives of the errors still works and this is a question for future research. However, due to the presence of the safety distance we believe that the bang-bang funnel controller also works in the presence of small errors in the measurement of the derivatives of the error; furthermore, we have already shown that the bang-bang funnel controller is robust with respect to time delays. Currently, the bang-bang funnel controller uses a logic which produces only two control values (corresponding to “decreasing” or “increasing” certain signals), but a more detailed logic could improve the performance of the closed loop. For example, one could add a third region in the funnel around zero and use a “neutral” value U_0 which keeps the error signals constant; promising experimental results using this idea are reported in [4]. Another interesting question is how the ideas of the bang-bang funnel controller can be generalized to also handle MIMO systems.

REFERENCES

- [1] Karl J. Åström. Event based control. In Alessandro Astolfi and Lorenzo Marconi, editors, *Analysis and Design of Nonlinear Control Systems*, pages 127–147. Springer-Verlag, 2008.
- [2] A.F. Filippov. *Differential equations with discontinuous right-hand sides*. Mathematics and Its Applications: Soviet Series, 18. Dordrecht etc.: Kluwer Academic Publishers, 1988.
- [3] Christoph M. Hackl, Norman Hopfe, Achim Ilchmann, Markus Mueller, and Stephan Trenn. Funnel control for systems with relative degree two. *SIAM J. Control Optim.*, 51:965–995, 2013.
- [4] Christoph M. Hackl and Stephan Trenn. The bang-bang funnel controller: An experimental verification. In *PAMM - Proc. Appl. Math. Mech.*, volume 12, pages 735–736, Weinheim, 2012. GAMM Annual Meeting 2012, Darmstadt, Wiley-VCH Verlag GmbH.
- [5] Norman Hopfe, Achim Ilchmann, and Eugene P. Ryan. Funnel control with saturation: linear MIMO systems. *IEEE Trans. Autom. Control*, 55(2):532–538, 2010.
- [6] Norman Hopfe, Achim Ilchmann, and Eugene P. Ryan. Funnel control with saturation: nonlinear SISO systems. *IEEE Trans. Autom. Control*, 55(9):2177–2182, 2010.
- [7] Achim Ilchmann, Eugene P. Ryan, and Christopher J. Sangwin. Tracking with prescribed transient behaviour. *ESAIM: Control, Optimisation and Calculus of Variations*, 7:471–493, 2002.
- [8] Achim Ilchmann, Eugene P. Ryan, and Philip Townsend. Tracking with prescribed transient behavior for nonlinear systems of known relative degree. *SIAM J. Control Optim.*, 46(1):210–230, 2007.
- [9] Achim Ilchmann and Stephan Trenn. Input constrained funnel control with applications to chemical reactor models. *Syst. Control Lett.*, 53(5):361–375, 2004.
- [10] Alberto Isidori. *Nonlinear Control Systems*. Communications and Control Engineering Series. Springer-Verlag, Berlin, 3rd edition, 1995.
- [11] Arie Levant. Universal single-input–single-output (SISO) sliding-mode controllers with finite-time convergence. *IEEE Trans. Autom. Control*, 46(9):1447–1451, 2001.
- [12] Daniel Liberzon and Stephan Trenn. The bang-bang funnel controller. In *Proc. 49th IEEE Conf. Decis. Control, Atlanta, USA*, pages 690–695, 2010.
- [13] Daniel Liberzon and Stephan Trenn. The bang-bang funnel controller (long version). preprint available from the websites of the authors, 2010.

- [14] Daniel Liberzon and Stephan Trenn. The bang-bang funnel controller: time delays and case study. to appear in Proc. 12th European Control Conference (ECC13), preprint available from the website of the authors, 2013.
- [15] Daniel E. Miller and Edward J. Davison. An adaptive controller which provides an arbitrarily good transient and steady-state response. *IEEE Trans. Autom. Control*, 36(1):68–81, 1991.
- [16] A. Stephen Morse. Overcoming the obstacle of high relative degree. *European J. Control*, 2(1):29–35, 1996.
- [17] Carmen Pedicini, Francesco Vasca, Luigi Iannelli, and Ulf T. Jönsson. An overview on averaging for pulse-modulated switched systems. In *Proc. 50th IEEE Conf. Decis. Control and European Control Conference ECC 2011, Orlando, USA*, pages 1860–1865, 2011.
- [18] V. I. Utkin. Variable structure systems with sliding modes. *IEEE Trans. Autom. Control*, AC-22:212–222, 1977.
- [19] Changjun Yu, Bin Li, Ryan Loxton, and KokLay Teo. Optimal discrete-valued control computation. *Journal of Global Optimization*, 2012. in press, published online.

APPENDIX

THE SWITCHING LOGIC FOR $r = 1$, $r = 2$ AND $r = 3$

For $r = 1$ the definition of \mathcal{S} results (by “merging” the definitions for \mathcal{S}_0 and \mathcal{S}_{r-1} in the right way) in the following DLS:

$$\begin{aligned} q(t) &= \mathfrak{S}(e(t), \varphi_0^+(t) - \varepsilon_0^+, \varphi_0^-(t) + \varepsilon_0^-, q(t-)), \\ q(0-) &= q^0 \in \{\text{true}, \text{false}\}, \end{aligned}$$

for $r = 2$ we obtain

$$\begin{aligned} q_1(t) &= \mathfrak{S}(e(t), \varphi_0^+(t) - \varepsilon_0^+, \varphi_0^-(t) + \varepsilon_0^-, q_1(t-)), \\ q_1(0-) &= q_1^0 \in \{\text{true}, \text{false}\}, \\ q(t) &= \begin{cases} \mathfrak{S}(\dot{e}(t), \min\{\varphi_0^+(t), -\lambda_1^-\} - \varepsilon_1^+, \varphi_1^-(t) + \varepsilon_1^-, q(t-)), & \text{if } q_1(t) = \text{true}, \\ \mathfrak{S}(\dot{e}(t), \varphi_1^+(t) - \varepsilon_1^+, \max\{\varphi_0^-(t), \lambda_1^+\} - \varepsilon_1^-, q(t-)), & \text{if } q_1(t) = \text{false}, \end{cases} \\ q(0-) &= q^0 \in \{\text{true}, \text{false}\}, \end{aligned}$$

and for $r = 3$

$$\begin{aligned} q_1(t) &= \mathfrak{S}(e(t), \varphi_0^+(t) - \varepsilon_0^+, \varphi_0^-(t) + \varepsilon_0^-, q_1(t-)), \\ q_1(0-) &= q_1^0 \in \{\text{true}, \text{false}\}, \\ q_2(t) &= \begin{cases} \mathfrak{S}(\dot{e}(t), \min\{\varphi_0^+(t), -\lambda_1^-\} - \varepsilon_1^+, \varphi_1^-(t) + \varepsilon_1^-, q_2(t-)), & \text{if } q_1(t) = \text{true}, \\ \mathfrak{S}(\dot{e}(t), \varphi_1^+(t) - \varepsilon_1^+, \max\{\varphi_0^-(t), \lambda_1^+\} + \varepsilon_1^-, q_2(t-)), & \text{if } q_1(t) = \text{false}, \end{cases} \\ q_2(0-) &= q_2^0 \in \{\text{true}, \text{false}\}, \\ q(t) &= \begin{cases} \mathfrak{S}(\ddot{e}(t), \min\{\varphi_0^+(t), -\lambda_2^-\} - \varepsilon_2^+, \varphi_2^-(t) + \varepsilon_2^-, q(t-)), & \text{if } q_1(t) \wedge q_2(t), \\ \mathfrak{S}(\ddot{e}(t), \varphi_2^+(t) - \varepsilon_2^+, \max\{\varphi_1^-(t), \lambda_2^+\} + \varepsilon_2^-, q(t-)), & \text{if } q_1(t) \wedge \neg q_2(t), \\ \mathfrak{S}(\ddot{e}(t), \min\{\varphi_1^+(t), -\lambda_2^-\} - \varepsilon_2^+, \varphi_2^-(t) + \varepsilon_2^-, q(t-)), & \text{if } \neg q_1(t) \wedge q_2(t), \\ \mathfrak{S}(\ddot{e}(t), \varphi_2^+(t) - \varepsilon_2^+, \max\{\varphi_0^-(t), \lambda_2^+\} + \varepsilon_2^-, q(t-)), & \text{if } \neg q_1(t) \wedge \neg q_2(t), \end{cases} \\ q(0-) &= q^0 \in \{\text{true}, \text{false}\}. \end{aligned}$$



Daniel Liberzon (M98-SM04-F13) was born in the former Soviet Union in 1973. He did his undergraduate studies in the Department of Mechanics and Mathematics at Moscow State University from 1989 to 1993. In 1993 he moved to the United States to pursue graduate studies in mathematics at Brandeis University, where he received the Ph.D. degree in 1998 (supervised by Prof. Roger W. Brockett of Harvard University).

Following a postdoctoral position in the Department of Electrical Engineering at Yale University from 1998 to 2000 (with Prof. A. Stephen Morse), he joined the University of Illinois at Urbana-Champaign, where he is now a professor in the Electrical and Computer Engineering Department and the Coordinated Science Laboratory. His research interests include nonlinear control theory, switched and hybrid dynamical systems, control with limited information, and uncertain and stochastic systems. He is the author of the books *Switching in Systems and Control* (Birkhauser, 2003) and *Calculus of Variations and Optimal Control Theory: A Concise Introduction* (Princeton Univ. Press, 2012).

Dr. Liberzon’s work has received several recognitions, including the 2002 IFAC Young Author Prize and the 2007 Donald P. Eckman Award. He delivered a plenary lecture at the 2008 American Control Conference. He has served as Associate Editor for the journals IEEE TRANSACTIONS ON AUTOMATIC CONTROL and MATHEMATICS OF CONTROL, SIGNALS, AND SYSTEMS.



Stephan Trenn was born in Germany in 1980. He received diploma degrees in mathematics (Dipl.-Math.) and computer science (Dipl.-Inf.) from the Ilmenau University of Technology, Ilmenau, Germany, in 2004 and 2006, respectively. At the same university he obtained his Ph.D. degree (Dr. rer. nat.) within the field of differential algebraic systems and distribution theory in 2009.

From 2004 to 2005, he was at the University of Southampton, U.K., for a six-month research visit. From 2009 to 2010 he stayed at the University of Illinois at Urbana-Champaign, USA, as a Postdoc and from 2010 until 2011 he was a research assistant at the University of Würzburg, Germany. Since December 2011 he has been an assistant professor (Juniorprofessor) at the University of Kaiserslautern, Germany. His research interest include differential-algebraic equations, switched systems and nonlinear control.

Dr. Trenn is Associate Editor for SYSTEMS & CONTROL LETTERS and serves on the editorial board of the Springer book series DIFFERENTIAL-ALGEBRAIC EQUATIONS FORUM.